



BMW UK
July 2014

THE NEW BMW X3 AND BMW X4.

PRODUCT OVERVIEW.

**BMW
GROUP**



EXCEPTIONALLY STRONG CUSTOMER APPEAL.

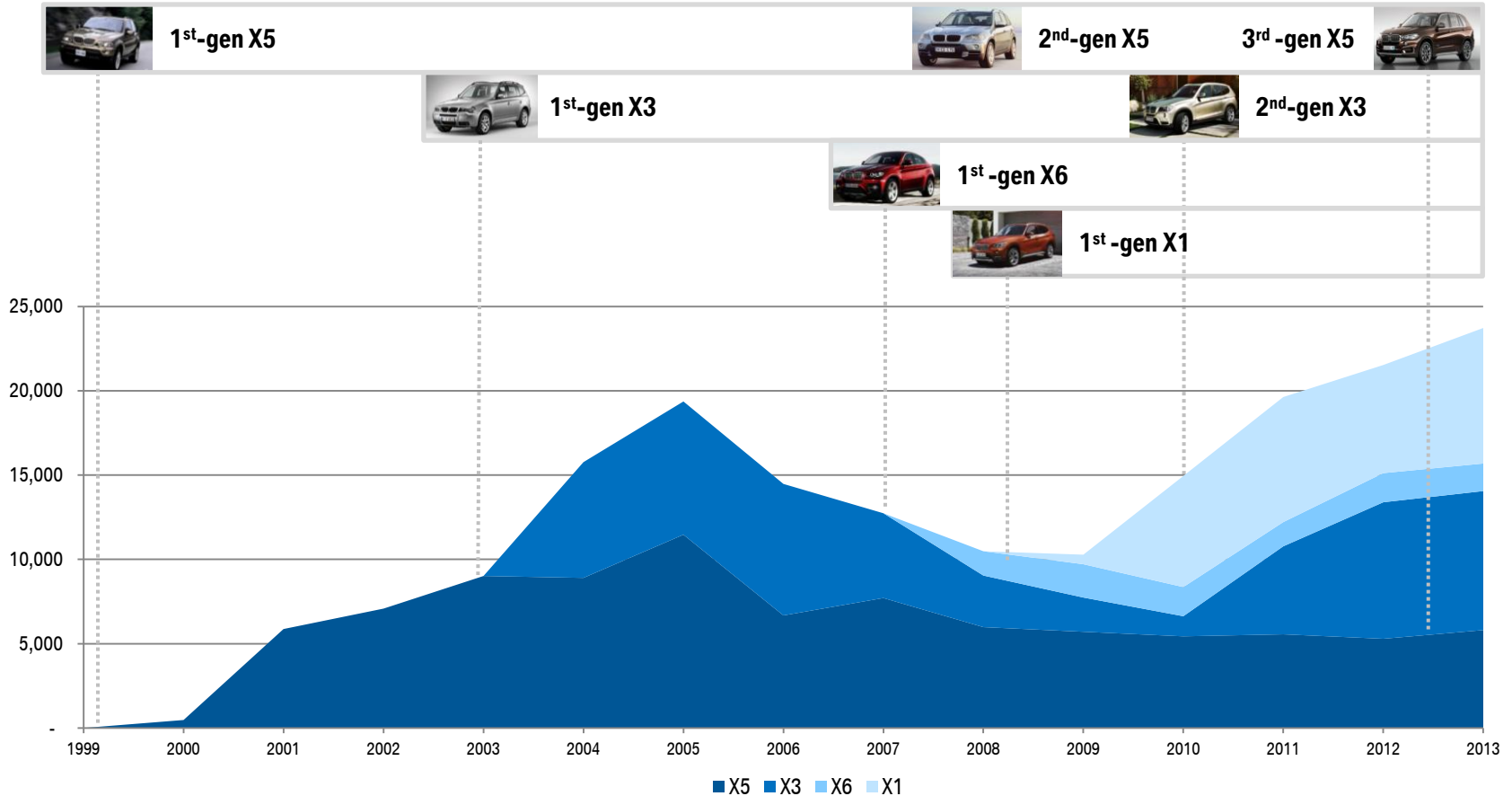

X3 – A VERY STRONG SALES SUCCESS SINCE LAUNCH.



Six month lead time

2013: Outsold Audi Q5

CAP RV: 50%

SIGNIFICANT EXTERIOR LCI CHANGES TO X3 SE.

Indicators into wing-mirrors.

New front headlight cluster and connection with new kidney grille frame.

Restyled lower bumper with additional inserts for xLine model.



LCI xLine

Pre-LCI SE

SPORTY INTERIOR AMBIENCE.



ADDITION OF xLINE TO MODEL LINE-UP.



M Sport +£3,000



SE



xLine +£1,500

MAJOR SPECIFICATION INCREASE FOR X3 LCI.



17" alloy wheels



Nevada leather upholstery



Media package – BMW Business



Two-zone A/C



Rain sensor/auto.headlight



xDrive status display



Cruise control



Bluetooth/USB



Drive Performance Control/ECO PRO



eCall



Front and rear PDC



DAB digital radio



Heated front seats



Automatic tailgate

NEXT-GENERATION TWINPOWER TURBO ENGINES.

Technical Data – 04/14 SOP						
	Engine	Transmission	Power [hp]	0-62mph [secs]	CO ₂ [g/km]	Combined [mpg]
X3 LCI	sDrive18d	MT	150 (+7)	9.5 (-0.4)	131 (-4)	56.5 (+1.1)
		AT		9.8 (-0.5)	133 (-9)	55.4 (+3.1)
	xDrive20d	MT	190 (+6)	8.1 (-0.4)	143 (-6)	52.3 (+1.9)
		AT		8.1 (-0.4)	138 (-9)	54.3 (+3.9)
	xDrive30d	AT	258	5.9 (-0.3)	156 (-3)	47.9 (+0.8)
	xDrive35d	AT	313	5.3 (-0.4)	157 (-5)	47.1 (+0.8)

- sDrive18d and xDrive20d feature next-generation 4-cyl TwinPower Turbo diesel engines.
- Next-generation modular engines based around 500cc cylinders in 3-cyl (eg, BMW i8), 4-cyl or 6-cyl configurations.

THE NEW BMW X4.



BMW LEADS CONCEPT INNOVATION IN SEGMENT.



UK SALES FORECAST.

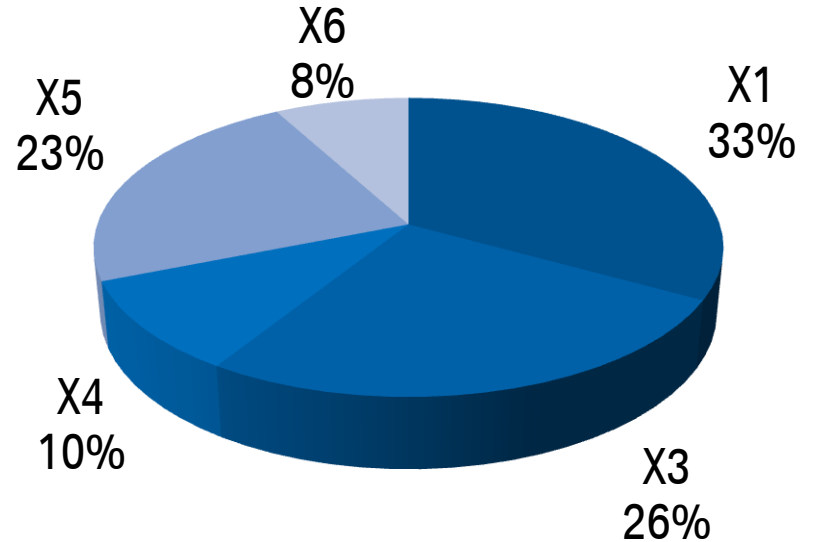
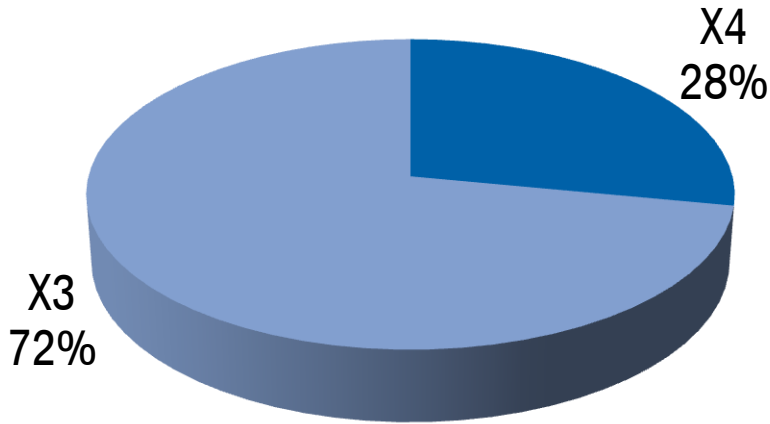

- Expected X4 sales of around 5,500 cars over four-year lifecycle.
- X4 peak year 2015 volume 2,000.

THE NEW BMW X4 SPORTS ACTIVITY COUPÉ.



AGGRESSIVE FRONT END.



SWEEPING COUPÉ PROFILE.



POWERFUL AND MUSCULAR STANCE.



X4 SEATS UP TO FIVE PEOPLE.



X4 SLIGHTLY LONGER AND LOWER THAN X3.

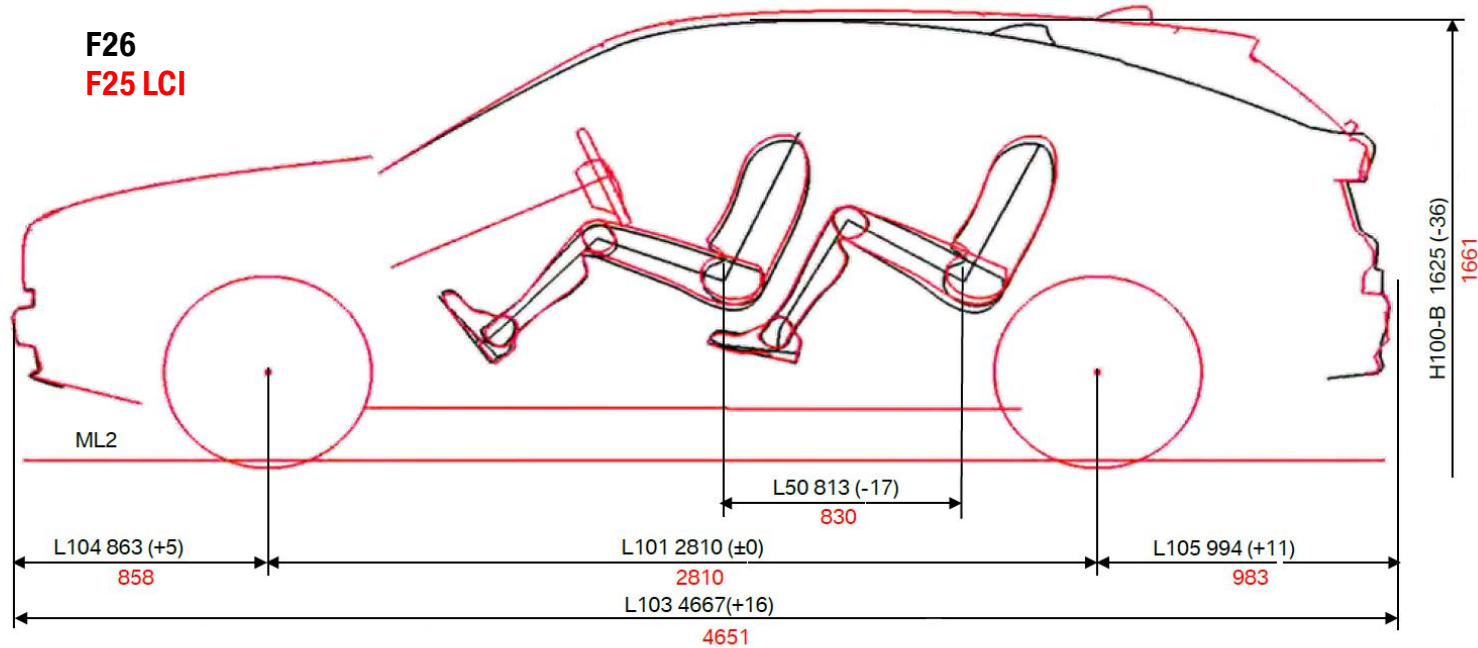

- Vehicle height **-36mm** versus X3.
- Boot capacity **500-1,400 litres** (50/200 litres less than X3)

- Vehicle length **+16mm** versus X3.
- Rear headroom **-44mm** versus X3.

ENGINE LINE-UP.



UK ENGINE LINE-UP INTRODUCTION.

2014

04/14

X3 LCI

sDrive18d

xDrive20d

xDrive30d

xDrive35d

X4

xDrive20d

xDrive30d

xDrive35d

07/14
Launch

Dates shown are Start of Production (SOP)

LATEST-GENERATION 4-CYLINDER DIESEL ENGINE.

Technical Data – 04/14 SOP						
	Engine	Transmission	Power [hp]	0-62mph [secs]	CO ₂ [g/km]	Combined [mpg]
X4	xDrive20d	MT	190	8.0	143	52.3
		AT		8.0	138	54.3
	xDrive30d	AT	258	5.8	156	47.9
	xDrive35d	AT	313	5.2	157	47.1

ENHANCED DRIVING DYNAMICS.

Lower centre of gravity vs. X3

=> more agile

Performance Control as standard on all models

=> improved cornering

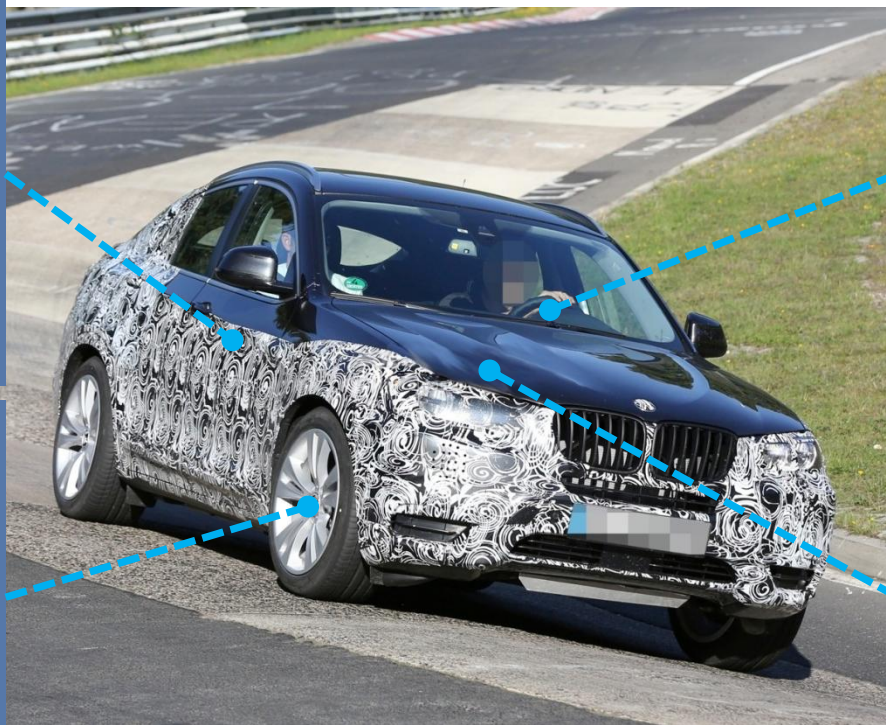

Variable Sport steering as standard on all models

=> better directional stability

Sport Automatic transmission with Launch Control

=> quicker acceleration

xDRIVE: INTELLIGENT ALL-WHEEL-DRIVE.

Permanently monitors which tyres have the most traction.

Automatically reacts to changes in traction in just **0.1 seconds**.

Delivers up to **almost 100%** of engine torque to either axle – wherever it's needed most.

xDrive status display shows pitch and roll angle, steering angle and compass.



OFFER STRUCTURE AND STANDARD EQUIPMENT.



X3 STANDARD EQUIPMENT CARRIED ACROSS TO X4.



17" alloy wheels



Nevada leather upholstery



Media package – BMW Business



Two-zone A/C



Rain sensor/auto.headlight



xDrive status display



Cruise control



Bluetooth/USB



Drive Performance Control/ECO PRO



eCall



Front and rear PDC



DAB digital radio



Heated front seats



Automatic tailgate

X4 RECEIVES SUBSTANTIAL ADDITIONAL EQUIPMENT.



18" alloy wheels



Xenon headlights



40:20:40 split-folding rear seats



Sport Automatic transmission (30d xLine)



Performance Control



Sport leather steering wheel

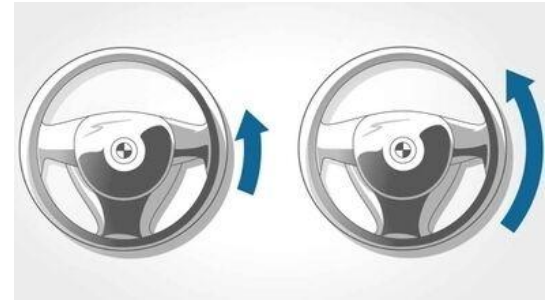

Variable Sport steering

MODEL LINE-UP.



M Sport +£3,000



SE



xLine +£1,500

EXTENSIVE RANGE OF ACCESSORIES.



THE LATEST BMW CONNECTED DRIVE TECHNOLOGIES.



BMW Professional Media package

Full range of ConnectedDrive Services

Real Time Traffic Information

iDrive Touch Controller

£900 (Business Media already standard)

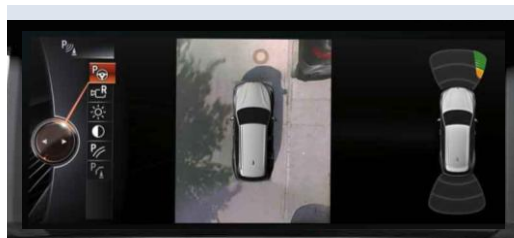

Surround-view

Full 360° 'Birds-eye' view

Front and rear view

Side view for tight junctions

£530

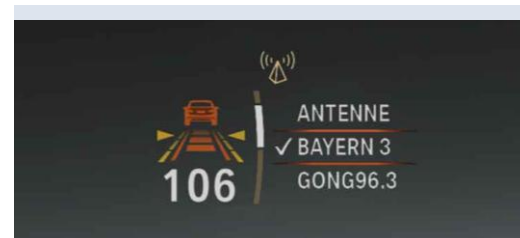

BMW Head-up Display

Full-colour TFT display

All relevant driver information displayed

Info and position can be adjusted

£935

PRICING.

Engine	Trim level	X3 OTR price	X4 OTR price	Difference vs. X3
xDrive20d	SE	£32,995	£36,595	+£3,600
xDrive30d	xLine	£41,295	£44,895	+£3,600
xDrive35d	M Sport	£45,395	£48,995	+£3,600

- Value of additional standard equipment over X3 is £2,180.



BMW UK
July 2014

THE NEW BMW X4.

THANK YOU FOR YOUR ATTENTION.

BMW
GROUP

