

# The new BMW 1 Series Convertible. Contents.



<b>1. Description in Brief.</b> .....	2
<b>2. A new Dimension of Open-Air Motoring Pleasure. The new BMW 1 Series Convertible. (Short Version)</b> .....	5
<b>3. Concept: The Most Sporting Convertible in its Class.</b> .....	18
<b>4. Design: Refreshingly new – but a Genuine BMW Convertible All the Same.</b> .....	21
<b>5. Drivetrain: Power and Efficiency for Unique Driving Pleasure.</b> .....	27
<b>6. Suspension and Driver Assistance Systems: Dynamics, Comfort and Safety Tailored to the Driver.</b> .....	36
<b>7. Body and Safety: Dependable Concept for Optimum Protection in Every Situation.</b> .....	41
<b>8. Features and Equipment: Fun with Style and Premium Quality.</b> .....	44
<b>9. Production: Flexible, Efficient and Environmentally Conscious.</b> .....	49
<b>10. Specifications BMW 1 Series Convertible.</b> .....	53
<b>11. Exterior and Interior Dimensions.</b> .....	57
<b>12. Power and Torque Diagrams.</b> .....	61



# 1. Description in Brief.

- Compact and extremely agile convertible in the BMW 1 Series; genuine four-seater with electrohydraulically operated soft top; first premium convertible in the compact segment; first open-air, compact BMW in the USA.
- Consistent expansion of the BMW 1 Series:  
The BMW 1 Series Convertible follows in the footsteps of the five-door, the three-door and the BMW 1 Series Coupé as the fourth model variant in the series. Offering features characteristic of BMW in a new dimension, the BMW 1 Series Convertible marks the authentic entry into the world of BMW Convertibles.
- Youthful, elegant design with all the features of BMW Convertible: slender silhouette, muscular wheel arches, strikingly powerful shoulder line. The low waistline and the big distance between the driver/front passenger and the windscreen ensure a unique experience of open-air driving pleasure in a BMW Convertible.
- Soft top opens and closes within 22 seconds. The roof may also be opened at speeds of up to 50 km/h, that is nearly always in city traffic. Optional, exclusive and absolutely unique roof variant in Anthracite with sewn-in gloss seams providing an interchanging silver effect in sunlight.
- Clear, generous interior design, high-quality trim and upholstery with a wide range of colours and materials; highly variable use ensured by optional through-loading including transport bag. Unique capacity in the luggage compartment and at the rear for a car in this segment, accommodating, say, two golf bags or two snowboards also when the roof is open.
- Wide range of leather upholstery and interior trim with Sun Reflective Technology reducing temperatures on the surface caused by bright sunshine. Automatic air conditioning with the special Convertible mode exclusive to BMW.
- Unique driving pleasure provided by rear-wheel drive and powerful engines: four gasoline engines (105 kW/143 hp–225 kW/306 hp), one four-cylinder turbodiesel (130 kW/177 hp) with particulates filter featured as standard.

- BMW EfficientDynamics on all engine variants; Brake Energy Regeneration featured specifically as appropriate on each model, Auto Start Stop, gearshift point indicator, Electric Power Steering (EPS), on-demand control of ancillaries and active aerodynamics reducing fuel consumption and exhaust emissions.
- Wide range of safety features all fitted as standard: airbags, belt latch tensioners, belt force limiters, rollover protection with rollbars moving up automatically behind the rear-seat headrests; crash-optimised front seat backrests and headrests reducing the risk of injury in a collision; extremely stiff and robust body structure.
- Wide range of audio, communication and navigation options quite unique in the compact segment, AUX-in and optional USB and Bluetooth interfaces featured as standard for simple connection/full integration of an Apple iPod and other MP3 players or Memory Sticks, controlled via BMW iDrive, eight favourite buttons for individual use by the driver.
- Elaborate chassis and suspension with rear-wheel drive; aluminium double-joint tiebar axle at the front; five-arm rear axle in lightweight steel structure; Dynamic Stability Control including Dynamic Traction Control; energy-saving electrical power steering with Servotronic; Active Steering exclusive to BMW as an optional extra; traction-optimised by electronically controlled locking function on the differential in the DSC-off mode on the BMW 135i Convertible.
- Top-of-the-range BMW 135i Convertible with modified M Aerodynamics Package and M Sports Suspension from the M Sports Package featured as standard equipment. Weight advantage: BMW 135i Convertible only 115 kg/254 lb heavier than BMW 135i Coupé.
- Engine variants:  
BMW 135i Convertible: straight-six gasoline engine with Twin Turbo and direct fuel injection (High Precision Injection)  
Capacity 2,979 cc, max output 225 kW/306 hp at 5,800 rpm,  
max torque 400 Nm/295 lb-ft from 1,300–5,000 rpm,  
acceleration 0–100 km/h in 5.6 seconds,  
top speed 250 km/h (155 mph) (electronically limited),  
average fuel consumption to EU standard 9.4 litres/100 km (30.0 mpg imp),  
CO<sub>2</sub> emissions to EU standard 224 g/km.

BMW 125i Convertible: straight-six gasoline with composite magnesium/aluminium crankcase, double-VANOS and VALVETRONIC  
Capacity 2,996 cc, max output 160 kW/218 hp at 6,100 rpm,  
max torque 270 Nm/199 lb-ft from 2,500–4,250 rpm,  
acceleration 0–100 km/h in 6.8 seconds,  
top speed 238 km/h (148 mph),  
average fuel consumption to EU standard 8.1 litres/100 km (34.9 mpg imp),  
CO<sub>2</sub> emissions to EU standard 195 g/km.

BMW 120i Convertible: straight-four gasoline engine with direct fuel injection (High Precision Injection) in the lean burn mode  
Capacity 1,995 cc, max output 125 kW/170 hp at 6,700 rpm,  
max torque 210 Nm/155 lb-ft at 4,250 rpm,  
acceleration 0–100 km/h in 8.4 seconds,  
top speed 220 km/h (136 mph),  
average fuel consumption to EU standard 6.6 litres/100 km (42.8 mpg imp),  
CO<sub>2</sub> emissions to EU standard 158 g/km.

BMW 118i Convertible: straight-four gasoline engine with direct fuel injection (High Precision Injection) in the lean burn mode  
Capacity 1,995 cc, max output 105 kW/143 hp at 6,000 rpm,  
max torque 190 Nm/140 lb-ft at 4,250 rpm,  
acceleration 0–100 km/h in 9.3 seconds,  
top speed 210 km/h (130 mph),  
average fuel consumption to EU standard 6.3 litres/100 km (44.8 mpg imp),  
CO<sub>2</sub> emissions to EU standard 149 g/km.

BMW 120d Convertible: straight-four diesel engine with turbocharging and common-rail direct fuel injection, diesel particulates filter featured as standard  
Capacity 1,995 cc, max output 130 kW/177 hp at 4,000 rpm,  
max torque 350 Nm/258 lb-ft from 1,750–3,000 rpm  
acceleration 0–100 km/h in 8.1 seconds,  
top speed 222 km/h (138 mph),  
average fuel consumption to EU standard 5.1 litres/100 km (55.4 mpg imp),  
CO<sub>2</sub> emissions to EU standard: 134 g/km.

## 2. **A new Dimension of Open-Air Motoring Pleasure. The new BMW 1 Series Convertible. (Short Version)**



Open-air motoring is now becoming a particularly intense experience also in the compact class. For the new BMW 1 Series Convertible offers sheer motoring pleasure in the most glorious sunshine and with the wind rushing by in new style and in a brand-new segment – thrillingly dynamic, elegantly styled, and as open as only a BMW Convertible can be.

This new two-door in the BMW range combines its dynamically stretched lines with the outstanding agility of the only compact car in the market with rear-wheel drive. A new benchmark in sports motoring is set above all by the top-of-the-range BMW 135i Convertible powered by BMW's 225 kW/306 hp 3.0-litre straight-six with Twin Turbo and direct gasoline injection, recognisable from outside by the slightly modified M Aerodynamics Package featured as standard as well as the entire body of the car lowered by 15 millimetres or almost 0.6" on account of the M Sport Suspension also featured as standard.

The range of engines is rounded off by another six-cylinder developing 160 kW/218 hp in the BMW 125i Convertible, two newly developed four-cylinders with direct gasoline injection and output of 125 kW/170hp in the BMW 120i Convertible and, respectively, 105 kW/143 hp in the BMW 118i Convertible, as well as a new-generation four-cylinder diesel offering 130 kW/177hp in the BMW 120d Convertible.

As the fourth model in the range, following the five-door, the three-door and the Coupé, the BMW 1 Series Convertible is now continuing the highly successful story of this model series. As the first premium convertible in the compact segment, the new BMW 1 Series Convertible provides a dynamic entry into the typical experience of driving a BMW Convertible, interpreting the brand values so characteristic of BMW in a particularly youthful and aesthetic manner.

This is also a result of the high-quality, stylish soft roof accentuating the overall sporting impression of this two-door performer. Offering exceptionally good noise reduction and comfort in winter, the soft top opens and closes electro-hydraulically in just 22 seconds – if necessary also while driving: The process of opening the roof can be activated at a speed of up to 40 km/h or 25 mph, then being continued up to a speed of 50 km/h (31 mph), that is in virtual all situations when driving in town.

As an alternative to the classic Black or Beige roof colours, a further option is Anthracite with a Silver effect. On this soft top quite unique the world over and exclusive to the BMW 1 Series Convertible, the cloth tissue is enhanced by fine gloss thread giving the material a particularly stylish, metal-glistening surface flair for attractive reflections in sunlight.

The low shoulder-line running parallel to the road and the dynamic design of the soft top give the BMW 1 Series Convertible a very sleek and slender appearance. In addition the low waistline adds to the open style so characteristic of a BMW Convertible, offering the driver as well as the front and rear passengers in this four-seater a far more intense and enjoyable experience of open-air motoring than is otherwise the case in a compact convertible.

The short and relatively steep windscreen frame further enhances this experience of open-air motoring through the generous distance it keeps to the heads of the driver and front passenger – and offers them a free, unobstructed view of the sky above.

**Exterior design: clearly recognisable as a BMW at very first sight.**

In its compact dimensions, the BMW 1 Series Convertible stands out not only through its size, but also through its proud, self-confident design. Indeed, the design language of the entire model series comes out in a particularly clear look, enhanced to an even higher standard of sporting elegance in the Convertible.

The characteristic features of the front air dam, the side-sills and the rear air dam are identical to the corresponding features on the BMW 1 Series Coupé. The entire silhouette of the car with its long, frameless doors bears clear testimony to rear-wheel drive quite unique in this segment, the tense, convex-concave surfaces being optically tightened by muscular wheel arches. This gives all flanks of the car a truly athletic look, with only a bit of the car's mass above the wheels.

The shoulder-line is particularly low for a car in this segment, adding a further touch of stretched elegance and augmenting the typical elegance of a genuine BMW Convertible.

The shoulder-line stretches all the way from the engine compartment lid to the rear lid, connecting the front and rear sections and, through its broad contours, forming a distinctive surface surrounding the entire interior. Looking at the new BMW 1 Series Convertible from an elevated position,

therefore, the strongly contoured shoulder-line creates the touch of a boat deck. As a result of this special look, the design of the car takes up the incomparably direct experience of the sun and wind presented in particularly authentic style.

**Optical effect of the soft top characterising the contours of the rear end.**

The rear look of the BMW 1 Series Convertible is characterised largely by the optical effect of the soft top: As long as the roof is open, the horizontal lines at the rear generate their full effect – and since the roof disappears completely into the luggage compartment, the BMW 1 Series Convertible looks particularly flat and sporting from behind.

As soon as the soft top is closed, the contours of the car growing wider to the bottom come out even more clearly, the 1 Series Convertible thus showing even stronger orientation to the wheels and exuding a particular touch of power and muscle.

On the rear lid a discreetly chiselled spoiler edge complete with the integrated third brake light accentuates the short and dynamic design of the rear end and, at the same time, ensures additional downforce on the rear wheels at high speeds. Within the L-shaped rear-light clusters the reversing lights and direction indicators stand out as a joint white band. The rear lights also encompass light rods fed by LED illumination units.

The wide range of body and interior colours clearly underlines the youthful character of the new BMW 1 Series Convertible, powerful colours and intense contrasts between the exterior and the interior generating a particular effect on this model interacting with the exciting design and the driving experience characterised by superior agility.

The exclusive body colours Cashmere Silver and Sedona Red Metallic unique to the BMW 1 Series Convertible give the car a particularly extroverted look.

**BMW 135i Convertible featuring the BMW M Sports Package as standard.**

As by far the most sporting model within the range of new 1 Series Convertibles, the BMW 135i Convertible stands out in particular through its M Aerodynamics Package featured as standard in modified form as a derivative of the M Sports Package. The special features setting this model so clearly apart from the other models in the range include the larger central air intake as well as smaller air scoops at the sides bordering on slightly protruding flaps.

An additional light edge on the side-sills visually lowers the height of the side panels, again emphasising the dynamic character of the car. And last but certainly not least, a diffuser integrated in the rear dam as well as tailpipe covers finished in dark chrome further enhance the sporting and elegant overall impression.

**Interior design: premium quality with sophisticated materials.**

The concepts of the body and interior design on the BMW 1 Series Convertible interact with one another and support each other in their mutual effect.

Proceeding from the BMW 1 Series Coupé, the interior design has been appropriately modified to meet the requirements of an open-air vehicle. The transition from the exterior to the interior is embellished on the BMW 135i Convertible and the BMW 125i Convertible by particularly attractive Chrome Line featured as standard on these models and available as an option on the four-cylinders. And in conjunction with this very stylish and sophisticated Chrome Line, the belt guides on the front seats are also finished in chrome.

Featuring high-quality materials, clear structures and proven, functional solutions, the interior has all the style and flair otherwise to be found only in much higher segments of the market. High-quality surface grain on the instrument panel, door linings and centre console, as well as galvanised pearl gloss surfaces integrated harmoniously into the car, give the interior a particular look and feel of quality and add to the ambience of sheer generosity.

Focusing specifically on the Convertible, the optional leather upholstery on the seats has been extended to include the armrests on the centre console and the doors, the particular touch of quality and sophistication provided in this way being rounded off by decorative seams.

**A special convertible feature:  
seat leather in Sun Reflective Technology.**

Exclusive features such as Sun Reflective Technology come straight from BMW Individual. After being successfully introduced into the market on the BMW Individual 6 Series Convertible, this unique technology with its benefits so important to the driver and passengers now also comes on all leather upholstery variants of the compact BMW 1 Series Convertible, preventing the leather from heating up in the sun.



BMW is the first carmaker in the world to offer this technology in large-scale production. Special cooling pigments integrated in the material serve in this case to reduce the build-up of higher temperatures on the surface as a result of sunshine by up to 20°C, even when the car is parked in the sun for a long time with the roof open. In practice this means that the leather will become warm after being exposed to the sun for a long period, but not hot.

The automatic air conditioning in the BMW 1 Series Convertible features a special convertible mode for use with the roof down. As soon as the driver selects this particular operating mode, ventilation control depends less on the current temperature within the interior, and is geared more to the outside temperature and the intensity of sunshine.

The optional wind deflector on the new BMW 1 Series Convertible serves above all to reduce air swirl within the interior at high speeds. Whenever necessary, the driver simply has to fasten the deflector on mounts in the side panels to keep it securely in position – a simple and convenient operation.

**Through-loading with a transport bag:  
more space for sports equipment.**

Offering luggage compartment capacity of 260 litres or 9.1 cu ft, the BMW 1 Series Convertible provides very generous loading space also with the roof down, unparalleled by any other convertible in this segment. And with the roof compartment cover swivelling up when not required, storage space in the luggage compartment can be increased to no less than 305 litres or 10.7 cu ft whenever the soft top is closed.

A specially developed rear-seat backrest gives the BMW 1 Series Convertible even greater functionality again quite unique in this part of the market. The optionally available through-loading to the rear-seat area is higher and wider than a conventional through-loading unit of this kind and the transport bag included in this option is large enough to house, say, two snowboards.

With the exception of the BMW 135i Convertible, a luggage rack fitting on all models helps to offer even more comprehensive transport requirements and take up even bulkier loads. Available as an Original BMW Accessory, this luggage rack fits conveniently at the rear, serving, for example, to take along two bicycles fitted securely on the car.

**BMW EfficientDynamics: Brake Energy Regeneration, Auto Start Stop and gearshift point indicator all featured as standard.**

All gasoline and diesel engines available for the new BMW 1 Series Convertible offer superior performance, outstanding efficiency and excellent motoring refinement in typical BMW style. Developed as part of the BMW EfficientDynamics strategy, these engines come with a wide range of innovations serving to optimise both fuel consumption and emissions.

The various features for enhancing efficiency are used in appropriate, model-specific combinations and come as standard in all cases. They serve to reduce weight, involve re-designed combustion chambers, help to optimise the fuel/air mixture process by means of third-generation common-rail fuel injection, VALVETRONIC or High Precision Injection, and ensure precise control of the combustion and air flow processes. In addition, the various improvements introduced in the context of BMW EfficientDynamics also encompass the ancillary units surrounding the engine.

Brake Energy Regeneration is one of the efficiency-enhancing measures featured as standard on every BMW 1 Series Convertible. This system concentrates the generation of electricity for the on-board network on phases of overrun and application of the brakes, thus serving to generate energy without burning any fuel. As long as the engine is pulling the car, the alternator is generally disengaged in order to provide more power and pulling force for the sheer driving pleasure so typical of BMW and at the same time to save energy and reduce exhaust emissions.

On manual models driven by one of the new four-cylinder power units, Auto Start Stop provides greater efficiency above all in city traffic. This system switches off the engine automatically whenever it is not required, thus reducing fuel consumption to zero when otherwise the engine would be idling. So whenever the driver, coming to a stop, say, at the traffic lights, shifts to neutral and takes his foot off the clutch, the engine's electronic "brain" will switch off the power unit. And then, to start again, all the driver has to do is press down the clutch pedal.

Another feature on manual gearbox versions of the new BMW 1 Series Convertible is the gearshift point indicator likewise coming as standard. This special function informs the driver of the best point for shifting gears in the interest of enhanced economy by way of arrow symbols in the instrument cluster.

Depending on the model variant, the BMW 1 Series Convertible offers additional features helping to reduce fuel consumption even further without requiring any action on the part of the driver. These include active control of the air flaps in the radiator grille opened only when the engine shows greater demand for cooling air. When closed, on the other hand, the flaps serve to optimise the car's streamlining.

On-demand use and operation of numerous ancillaries likewise helps to increase the level of efficiency and all-round economy. On all model variants with the exception of the BMW 135i Convertible the EPS Electric Power Steering consumes energy only when steering assistance is actually required. And on the new gasoline engines, the new electric coolant pump operates not as a function of engine speed, but rather in accordance with engine temperature, that is only when really necessary.

Even the a/c compressor, finally, helps to save energy, being connected to the drive belt by a clutch only when the air conditioning is actually in use.

### **BMW 135i Convertible: BMW's most powerful straight-six.**

The most sporting model within the new series is of course the BMW 135i Convertible powered by the most dynamic and muscular straight-six within BMW's wide range of engines. With its combination of Twin Turbo technology and High Precision Injection, this light-alloy power unit offers a level of technology quite unique the world over in this engine category.

Displacing 2,979 cubic centimetres, the engine weighing just 185 kg/408 lb develops maximum output of 225 kW/306 hp at an engine speed of 5,800 rpm, plus maximum torque of 400 Newton-metres/295 lb-ft throughout the very broad engine speed range from 1,300–5,000 rpm.

Incomparably spontaneous acceleration, a fascinating surge of power from the ground up and far beyond, as well as literally inexhaustible muscle up to maximum engine speed of approximately 7,000 rpm characterise the unique driving experience offered by BMW's open-air two-door model with this engine variant: Acceleration to 100 km/h in the BMW 135i Convertible comes in just 5.6 seconds and top speed is limited electronically, to 250 km/h or 155 mph.

This clearly places the top model well in the realms of high-class thoroughbred sports cars, while fuel consumption is reduced to a minimum in comparison with other models in this segment: Average fuel consumption in the EU test cycle of just 9.4 litres/100 kilometres (equal to 30.0 mpg imp)

shows that the BMW EfficientDynamics development strategy is able to offer impressively good fuel economy also on an extremely powerful high-performance model.

The power unit of the BMW 135i Convertible is the first and only straight-six gasoline engine in this segment with Twin Turbo technology providing power, muscle and performance quite comparable to that of a much larger normal-aspiration engine.

High Precision Injection serves as the key function in the efficient use of fuel, this second-generation of direct gasoline injection using injectors positioned directly next to the spark plugs in the cylinder head and delivering fuel into the combustion chambers at a pressure of 200 bar in the interest of extremely precise fuel dosage.

Over and above its supreme power, the BMW 135i Convertible comes as standard with a wide range of further features giving the car its unique driving characteristics. Apart from the modified M Aerodynamics Package, these include the M Sports Package, the individual set-up of DSC Dynamic Stability Control, the electronically controlled locking function on the differential, the more direct control map for Servotronic power assistance specifically geared to this model, and the even more spontaneous response of the gas pedal.

**BMW 125i Convertible:  
alternative normal-aspiration engine in the six-cylinder league.**

The new BMW 125i Convertible also features a straight-six power unit within its engine bay. In this case the normal-aspiration power unit develops maximum output of 160 kW/218 hp at 6,100 rpm from 2,996 cubic centimetres together with maximum torque of 270 Newton-metres/199 lb-ft maintained consistently at 2,500 rpm.

This kind of power gives the BMW 125i Convertible a top speed of 238 km/h or 148 mph, with acceleration to 100 km/h in just 6.8 seconds.

Weighing only 161 kg or 355 lb, this six-cylinder with its composite magnesium/aluminium crankcase makes an important contribution to the harmonious distribution of axle load on the BMW 125i Convertible, enhancing the car's agile driving behaviour.

Consistently developed to an ever-increasing standard, fully variable VALVETRONIC valve management and the electric coolant pump operating on demand are further superior technologies serving to enhance engine efficiency.

With its average fuel consumption of 8.1 litres/100 kilometres, equal to 34.8 mpg imp, the BMW 125i Convertible offers all the supremacy of a six-cylinder with particularly economical qualities.

**BMW 120i Convertible and BMW 118i Convertible:  
four cylinders of the highest calibre.**

Moving on to the four-cylinder gasoline engines for the new BMW 1 Series Convertible, BMW's engine development specialists again focused on High Precision Injection. Displacing 1,995 cubic centimetres, this light-alloy power unit is entering the market in two power stages, both of them featuring second-generation direct gasoline injection in the lean burn mode. This means that the fuel injected by piezo-injectors in a central position in the cylinder head fills the combustion chambers in different layers varying in concentration. In all cases there is an ignitable fuel/air mixture only in the immediate vicinity of the spark plug. After ignition, however, the leaner fuel/air mixture layers further away from the spark plug are also included in the combustion process.

The crankcase on both engine variants is made of aluminium, the biggest difference in construction being the use of a switchable intake manifold on the more powerful version.

The four-cylinder power unit in the BMW 120i Convertible develops 125 kW/170 hp at an engine speed of 6,700 rpm, with peak torque of 210 Newton-metres/155 lb-ft at just 4,250 rpm. This allows acceleration to 100 km/h in 8.4 seconds, with a top speed of 220 km/h or 136 mph.

Fuel consumption of the new BMW 120i Convertible in the EU test cycle averages just 6.6 litres/100 kilometres, equal to 42.8 mpg imp, the CO<sub>2</sub> rating is 158 grams per kilometre.

Developing 105 kW/143 hp at 6,000 rpm and maximum torque of 190 Newton-metres/140 lb-ft at 4,250 rpm, the second four-cylinder again offers ideal conditions for sporting performance. Top speed of the BMW 118i Convertible is 210 km/h or 130 mph, with acceleration from 0–100 km/h in 9.3 seconds. Average fuel consumption in the EU test cycle is 6.3 litres/100 kilometres (equal to 44.8 mpg imp), and CO<sub>2</sub> emissions are 149 grams/kilometre.

**BMW 120d Convertible: featuring a particulates filter as standard.**

Displacing 1,995 cubic centimetres, the four-cylinder turbodiesel in the new BMW 120d Convertible develops 130 kW/177 hp at 4,000 rpm, with peak torque of 350 Newton-metres or 256 lb-ft between 1,750 and 3,000 rpm. Offering top speed of 222 km/h (138 mph), accelerating to 100 km/h in

8.1 seconds, and with average fuel consumption of 5.1 litres/100 kilometres (equal to 55.4 mpg imp), the new BMW 120d Convertible combines sporting performance with superior economy. Compared with other models in its performance class, the BMW 120d Convertible again ranks right at the top in terms of acceleration and fuel economy. Emissions are just as outstanding, with a CO<sub>2</sub> rating of just 134 grams/kilometre.

The power unit featured in the new BMW 120d Convertible comes with an exhaust gas turbocharger featuring variable turbine geometry to provide optimum power and muscle throughout all load ranges. Diesel fuel is injected by third-generation common-rail direct fuel injection using piezo-injectors operating at a pressure of 1,800 bar.

As a representative of the new generation of diesel engines, this high-tech power unit comes as standard with a diesel particulates filter positioned close to the engine, thus optimising the engine's emission management not only in terms of CO<sub>2</sub>.

#### **Dynamic automatic transmission with Steptronic.**

As an alternative to the manual gearbox, all engine variants featured in the new BMW 1 Series Convertible may be combined as an option with a dynamic six-speed automatic transmission. With its special converter technology, the automatic transmission not only reduces the loss of energy in transmitting engine power, but also shortens the reaction and gearshift times. And being connected directly to the engine, the transmission enhances the sporting character of the car just as the precise gearshift and choice of gears allows the driver to skip one or several gears in order to shift back as quickly as possible.

Using the Steptronic function, the driver is also able to shift gears manually either via the selector lever on the central console or via paddles on the steering wheel itself. Indeed, these paddles are standard on the BMW 135i Convertible with automatic transmission and come as an option on the BMW 125i Convertible with automatic. A further point is that on the BMW 135i Convertible the transmission is adjusted to a particularly sporting set-up whenever the driver changes to manual gear selection.

The automatic transmission available on the BMW 135i Convertible is particularly sporting and dynamic in its character. Indeed, this extra-precise automatic transmission already introduced on the new BMW 5 Series in spring 2007 stands out in particular through its extremely short gearshift times.

### **Elaborate suspension with EPS Electric Power Steering and Active Steering as an option.**

The sporting character of the BMW 1 Series Convertible also results from the transmission of drive power to the rear wheels quite unique in the compact segment. The technical standard of the chassis and suspension is likewise quite unparalleled, the rear axle featuring a five-arm configuration carefully geared to the specific requirements of the engines with their outstanding power and torque.

The final drive differential comes from a new generation of axle transmissions presented upon the introduction of the 1 Series, optimised running smoothness and the use of double-helical ball bearings for the first time serving to reduce operating temperatures and increase both functionality and the service life of the final drive.

Combined with an anti-roll bar, the double-joint spring strut tiebar axle at the front is made largely of aluminium. This not only reduces weight to a minimum, but also ensures a high standard of stiffness on all components.

A new feature is Electric Power Steering with an integrated Servotronic function for speed-related steering assistance. EPS enhances the level of precision and comfort in the steering process and at the same time reduces fuel consumption. Contrary to a conventional mechanical-hydraulic steering system, power assistance is provided in this case by an electric motor operating only when required.

As an option the BMW 1 Series Convertible is available with Active Steering developed by BMW in the interest of even greater precision and steering comfort particularly in city traffic. For while Servotronic steering featured as standard acts on the steering forces required of the driver, Active Steering varies the steering transmission ratio as a function of road speed.

### **Dynamic driving programs help the driver control the car.**

DSC Dynamic Stability Control comes as a standard feature on the BMW 1 Series Convertible preventing the rear of the car from swerving round in a critical situation (oversteer) or the car "pushing" over the front wheels (understeer) by applying the brakes specifically on individual wheels and reducing engine power accordingly.

DSC also comprises the anti-lock brake system (ABS) for the brakes, ASC Automatic Stability Control preventing an individual drive wheel from spinning when setting off, CBC Cornering Brake Control stabilising the

car if necessary when applying the brakes in a bend, and DTC Dynamic Traction Control serving whenever required to optimise the car's drive forces on the road.

An important point is that DSC Dynamic Stability Control in the new BMW 1 Series Convertible may be completely deactivated when required at the touch of a button.

### **Electronically controlled differential locking function enhancing traction on the BMW 135i Convertible**

To ensure optimum traction in view of the engine's high power and muscular torque, the BMW 135i Convertible comes with various technologies serving to improve traction to the highest standard. In particular, this allows the driver to choose a sporting and ambitious style of motoring, for example when accelerating out of a bend or hairpin.

An electronically controlled locking function on the differential ensures optimum traction whenever DSC Dynamic Stability Control is switched off completely, applying the brakes specifically and appropriately on a drive wheel spinning in tight bends. In this case the power not required is conveyed to the other drive wheel still benefiting from adequate grip. This promotes the car's driving force without exerting a negative influence on its steering behaviour.

The BMW 120i Convertible, the BMW 118i Convertible and the BMW 120d Convertible all come with 16-inch wheels, the two six-cylinder models feature 17-inch light-alloy wheels as standard. In addition, the BMW 135i Convertible boasts not only the M Sports Suspension again fitted as standard, but also a high-performance brake system made up of six-piston fixed-callipers at the front and two-piston fixed callipers at the rear. The ASC and DSC driving stability system are also set up differently in this case, taking the particularly sporting character of the BMW 135i Convertible into account.

### **Supreme quality also in terms of safety.**

High-strength steel, additional reinforcements and special deformation elements serve to absorb most of the impact energy in a severe collision, diverting the energy to defined load paths and thus keeping it away from the passenger cell.

In terms of torsional stiffness, the BMW 1 Series Convertible achieves a standard quite comparable to the supreme level already offered by the BMW 3 Series Convertible with its truly outstanding driving dynamic and superior safety. A further point is that the new BMW 1 Series Convertible naturally fulfils all legal standards and requirements in the international



automobile markets in both active and passive safety. As a result, the new model has everything it takes for excellent results in all crash tests relevant the world over.

Restraint systems carefully harmonised to one another and masterminded by central safety electronics ensure maximum occupant safety on all four seats. Four airbags – frontal airbags activated in two stages and side airbags integrated in the front seat backrests – come as standard for optimum safety within the new BMW 1 Series Convertible.

The new BMW 1 Series Convertible also comes as standard with crash-optimised seat backrests and headrests.

Rollover sensors in the BMW 1 Series Convertible permanently monitor the vertical and horizontal movements of the car. As soon as the safety electronics register the risk of a rollover, two rollbars normally hidden behind the headrests at the rear move up within fractions of a second. The elegant silhouette of the new BMW 1 Series Convertible is thus combined perfectly with the superior safety concept of the car.

Available as an option, the bi-xenon main headlights, just like the Adaptive Head-lights including Bending Lights, make driving in the dark in city traffic or on country roads even safer than before. Indeed, the combination of these comfort and safety functions is quite unique in the compact car segment.

The daytime driving light featuring two corona rings in each headlight unit in that typical BMW look enhances the visibility of the car under normal and dusky light conditions. Two-stage brake lights, finally, warn motorists following from behind with a particularly clear signal whenever the driver is applying the brakes in an emergency.

**Premium entertainment: AUX-in connection and iPod interface.**

The audio systems available for the new BMW 1 Series Convertible come as an option with a USB interface supplementing the Aux-in connection provided as standard. This allows the driver and passengers to integrate various versions of the Apple iPod as well as external MP3 players completely into the car's audio system.

The iDrive control system featured in conjunction with an optional navigation system enables the driver, through the central Controller and by means of eight favourite buttons for individual use, to control all secondary and comfort functions in Communication, Air Conditioning, Entertainment and Navigation with particular ease and convenience.

### 3. **Concept: The Most Sporting Convertible in its Class.**



- **Consistent expansion of the BMW 1 Series.**
- **Attractive, youthful entry into the world of the BMW Convertible.**
- **Most sporting and sophisticated convertible in the compact segment.**

Greater driving dynamics, extra flair, added premium quality – the BMW 1 Series has truly enriched the compact class. Introducing the first and – to this day – only rear-wheel drive model in the range, BMW is significantly increasing the focus on sheer driving pleasure also in this segment.

In the meantime, following the five- and three-door models, the dynamic and successful story of this unique model series has been further enhanced by the BMW 1 Series Coupé. And now the fourth body variant adds further momentum and even greater appeal, offering the pleasure of open-air motoring in a particularly agile and dynamic premium convertible. Once again, therefore, the BMW 1 Series Convertible quite literally opens up the door – or, as you might say, the roof – to a driving experience never to be enjoyed before in this compact segment.

At the same time the new model enables the enthusiast to enter the world of the BMW Convertible right from the start in the compact class, in the guise of the BMW 1 Series Convertible. A car which, in its concept and design, boasts all the features typical of a BMW Convertible – features which give the new model fascinating elegance in its looks and an incomparable experience of sheer driving pleasure in the open air. Indeed, this direct enjoyment of the sun and wind meets all the expectations the car arouses from the start through its youthful and fresh design.

#### **A BMW Convertible all the way: incomparably open, uniquely dynamic.**

The BMW 1 Series Convertible is sporting, elegantly stretched, and harmoniously proportioned. In its design it interprets the brand values of BMW in a particularly youthful and aesthetic manner. This is further enhanced by the high-quality soft roof with its lines reflecting the sporting overall impression of this two-door performer.

Powered electrohydraulically, the soft top opens or closes at the touch of a button in just 22 seconds. A further advantage is that the roof may be operated while driving at a speed of up to 40 km/h or 25 mph, with the process of opening up continuing all the way to 50 km/h or 31 mph – that is under virtually all conditions in city motoring.

The low shoulder-line of the BMW 1 Series Convertible comes out particularly clearly with the soft top open. A further highlight is the low and dynamic waistline contributing to the openness so characteristic of a BMW Convertible. This offers the driver, the front passenger and the passengers at the rear of this four-seater a truly intense feeling of open-air motoring more fascinating than is generally the case in such a compact convertible.

The short and relatively steep windscreen frame likewise enhances this feeling of openness, in particular by keeping a significant distance from the heads of the driver and front passenger and therefore offering them a free and unobstructed view of the sky above.

The unmistakable character of the BMW 1 Series Convertible is also borne out by the sporting performance of the car again typical of the BMW brand. More consistently than any other convertible in its class, the BMW 1 Series Convertible capitalises on the options and benefits offered by its compact body. Featuring powerful engines and the most sophisticated suspension technology in this segment, low weight and harmonious axle load distribution, the new model offers an unprecedented standard of agility opening up the door to a brand-new feeling of sheer driving pleasure in typical BMW style.

This clear pledge to sporting performance comes out particularly in the top-of-the-range BMW 135i Convertible. With its 225 kW/306 hp 3.0-litre straight-six featuring Twin Turbo technology and High Precision Injection, this power unit clearly ranks right at the top of the segment. And in addition to its outstanding engine power and performance, the BMW 135i Convertible comes as standard with numerous further features making the car quite unique in its driving characteristics.

Over and above a number of distinctive features on the exterior, the modified M Aerodynamics Package, the M Sports Suspension, individual set-up of DSC Dynamic Stability Control, an electronically controlled locking function of the differential, a more direct control map for Servotronic steering assistance, and an even more spontaneous gas pedal control map all contribute to this unique quality. And last but certainly not least, the BMW 135i Convertible

benefits from minimum weight, with its extra weight over the BMW 135i Coupé of only 115 kg or 254 lb likewise contributing to the car's dynamic driving performance.

**BMW EfficientDynamics: the leader also in fuel economy.**

The engines available for this new member of the BMW 1 Series meet the greatest demands in every respect. The four-cylinder gasoline and diesel engines, for example, combine sheer driving pleasure with unparalleled fuel economy and emission management. The two six-cylinders, on the other hand, bring together outstanding efficiency with characteristic motoring refinement and a standard of performance unparalleled in the compact segment.

All drive units come with the latest technology developed in the context of BMW EfficientDynamics. Further improvements around the engine standard on all variants likewise help to reduce fuel consumption and emissions, among them Brake Energy Regeneration, Auto Start Stop, a gearshift point indicator, on-demand control of the engine's ancillary units, as well as active aerodynamics. No other model in the compact segment is able to offer a comparable package of efficiency-enhancing improvements.

**Premium quality and supreme function.**

The BMW 1 Series Convertible proves its superiority not only in terms of driving pleasure and efficiency, flair and quality, but also in its all-round functionality. The exterior and interior are finished in sophisticated, first-class style, the car offering a premium standard also in this respect.

Superior practical value likewise contributes to an ongoing experience of sheer driving pleasure in this compact two-door performer. Four comfortable seats, generous headroom and legroom also at the rear, a large number of storage options and above-average luggage capacity also with the roof open give the BMW 1 Series Convertible all the qualities required for long-distance motoring in genuine style.

Offering capacity of 260 litres or 9.1 cu ft, the luggage compartment takes up two full-size golf bags. And with the roof open and the panel between the roof compartment and the luggage compartment swivelled up, luggage capacity increases to an even more respectable 305 litres or 10.7 cu ft.

Even more luggage capacity is offered by the optional through-loading to the rear including a transport bag serving to accommodate, say, two snowboards without the slightest problem. And last but not least, the BMW 1 Series Convertible, thanks to its soft top very well-suited also for winter driving, is perfectly prepared also for long trips on a skiing holiday in winter.

## 4. Design: Refreshingly new – but a Genuine BMW Convertible All the Same.



- **BMW design language in young and sporting style.**
- **Unique: soft roof with integrated gloss thread.**
- **BMW 135i Convertible featuring M Aerodynamics Package as standard.**

In its compact dimensions, the BMW 1 Series Convertible stands out not through size, but rather through self-confident, superior design enhancing the entire model series in particularly elegant style. At the same time the BMW 1 Series Convertible offers a young and sporting interpretation of the flair so typical of a BMW Convertible in general.

The low and elegantly stretched silhouette is enhanced by the dynamic lines of the soft top, the entire look of the BMW 1 Series Convertible expressing both outstanding driving dynamics and premium character quite unique in the compact segment.

Features typical of the BMW 1 Series add to the design of this open-air two-door and enhance the low waistline so typical of a BMW Convertible, giving the occupants both front and rear an incomparably intense driving experience in the open air. The BMW 1 Series Convertible thus catches the eye at very first sight through its attractive looks and design bearing reference right from the start to supreme driving pleasure. Indeed, the design of the car follows authentically from BMW's history of outstanding Convertibles and sets new highlights in the compact segment.

### **Exterior design: BMW brand values in their most youthful form.**

Again typical of the entire model series, the front end of the compact BMW 1 Series Convertible offers an open and active impression. The characteristic features of the car are identical to the corresponding details on the BMW 1 Series Coupé, the front air dam with its large air intakes and the two openings at the side expressing a superior look of sportiness.

The generous, free surfaces to be found here without any separation by the bumper or impact bar give the BMW 1 Series Convertible a face of genuine clarity. The headlights in their dark surrounds are full of expression and show a clear focus on the road, with their chrome-embellished tubes standing out attractively.

The tense contours of the kidney grille, finally, also bear clear testimony to the outstanding agility and dynamism of the BMW 1 Series Convertible.

Stretched, frameless doors guide the eyes of the beholder to the rear section of the car, emphasising the philosophy of rear-wheel drive quite unique in the compact segment. Through the length of the doors and the long engine compartment lid, the position of the driver's seat looks as if it had been moved even further back in the interest of sporting performance and character. The convex-concave surfaces interacting with one another are tightened additionally in visual terms by the muscular wheel arches. The flanks of the car, in turn, look truly athletic in style, with only very little body mass above the wheels.

Again in comparison with other cars in the segment, the shoulder-line is particularly low, enhancing the stretched and sleek overall impression of the BMW 1 Series Convertible and the elegance so typical of open-air models from BMW.

**Shoulder-line reminiscent of a boat deck taking up the feeling of the sun and wind.**

The shoulder-line stretches from the engine compartment all the way to the rear lid, connecting the front and rear ends and, through its sheer width alone, forming a bold perimeter encompassing the entire interior. Looking at the new BMW 1 Series Convertible from an elevated position, therefore, one perceives the strongly flared shoulder-line as similar to the deck of a boat, the design of the car thus taking up and reinforcing the incomparably direct experience of the sun and wind.

**Optical effect of the soft top characterising the contours at the rear.**

Through its dynamic line and sleek elegance, the soft top makes a significant contribution to the slender overall impression of the open-air BMW 1 Series. As long as the roof is open, the horizontal body lines at the rear are able to bring out their full effect and impact. And since the soft roof moves down completely into the luggage compartment, the BMW 1 Series Convertible looks particularly flat, sporting and elegant also from behind. When the roof is closed, on the other hand, the contours growing wider towards the rear become even more significant, with the design and shape of the Convertible showing strong orientation to the wheels and a great sense of power.

A spoiler lip discreetly chiselled into the bootlid with its integrated third brake light emphasises the short and compact design of the rear end and helps to provide additional downforce at high speeds. Horizontal light bars in the middle and lower rear area, in turn, offer an optical counter-balance to the shape of the spoiler edge clearly swinging upwards.

The L-shaped rear-light clusters incorporate the back-up lights and direction indicators as one common white band, the rear lights also encompassing light conductors fed by the LED units. So benefiting from this particular structure of the light sources so typical of the brand, the new BMW 1 Series Convertible stands out clearly as a BMW also at night.

**Unique the world over: soft top with integrated gloss thread.**

As a genuine premium model, the BMW 1 Series Convertible offers surprising features and highlights in design. One example is the roof in Anthracite with a special silver effect as a unique embellishment exclusive worldwide to the BMW Convertible and adding a very special touch.

On this variant available as an option at only low extra cost, the high-quality cloth on the roof incorporates fine gloss threads giving the material a particularly sophisticated, glistening metallic surface effect for attractive reflections in the sun.

In standard trim the soft roof on the BMW 1 Series Convertible comes in classic Black or Beige.

The wide range of body and interior colours available on the new BMW 1 Series Convertible underlines the young character of the car: Powerful colours and intense contrasts between the exterior and interior give this model a special effect perfectly matched to the driving experience so full of unique agility.

The BMW 1 Series Convertible shows particularly extroverted style in Cashmere Silver and Sedona Red Metallic, two special colours exclusive to this model. Through its Beige nuances, the innovative, glistening Silver colour gives the BMW 1 Series Convertible a particularly elegant and avantgarde look, while the paintwork in powerful and warm Red adds unlimited vitality and joy of life.

Over and above these exclusive colours, the Convertible is available in Black, White, brilliant Carmesine Red and in the metallic colours Titanium Silver, Montego Blue, Sparkling Graphite, Crystal Blue, Tahiti Green, Monaco Blue and Sapphire Black.

**BMW 135i Convertible with M Sports Package features as standard.**

Showing the greatest focus on sporting performance of all model versions, the BMW 135i Convertible stands out in particular through its M Aerodynamics Package featured as standard and modified where appropriate as well as the M Sports Suspension carried over from the M Sports Package and lowering the entire vehicle by 15 millimetres or almost 0.6".

A particularly striking feature is the larger central air intake next to the numberplate cover sweeping up dynamically in a flowing line. The smaller air intakes at the sides, in turn, border on to slightly flared flaps, giving the front end of the BMW 135i Convertible an even wider look than the other model variants.

A further feature on the front end of the top model is the chrome-plated bars in the kidney grille.

The M Sports Package also comprises sporting side-sills in even more distinctive, flowing design. Incorporating an additional light edge, they further reduce the visual height of the side panels on the BMW 135i Convertible, adding further emphasis to the wide look of the car's silhouette.

The wide track of the car is accentuated particularly at the rear, with a diffuser integrated discreetly but very effectively in aerodynamic terms in the rear air dam beneath the bumper. Being finished in matt Anthracite, this diffuser adds a further touch to the side panels finished in body colour, drawing the eyes of the beholder even more to the wheels and the wide track of the car. Yet a further optical highlight is provided by the tailpipes on the exhaust finished in dark chrome.

**Interior design: premium quality with sophisticated materials.**

The interior of the BMW 1 Series Convertible forms an elegant unit merging into and out of the surrounding exterior surfaces. Hence, the car stands out from the beginning through its beautiful combination of lines and sculptured shapes when both open and closed.

Proceeding from the BMW 1 Series Coupé, the interior design has been modified to meet the requirements of an open car, the surfaces on the door sills starting at the windscreen continuing on to the rear in a very harmonious and convincing look.



The concepts of body and interior design thus interact and support one another in their effect, the design of the sills joining forces with the widely flared shoulder and the rear lid creating an overall impression of harmony and elegance.

The transition from the exterior to the interior is highlighted on the BMW 135i Convertible and the BMW 125i Convertible by Chrome Line trim offering a special touch of style and elegance. And the same feature coming as standard on these two models is also available as an option on the four-cylinders.

In combination with Chrome Line, the belt guides on the front seats are likewise finished in a sophisticated chrome gloss look.

The interior of the BMW 1 Series Convertible is characterised by clear lines as well as wide-sweeping, dynamic horizontal surfaces creating an open and generous atmosphere. With its high-quality materials, clear structure and proven, functional details, the interior, in its flair and sophisticated style, is quite comparable to that of other cars in higher segments of the market.

The upper part of the instrument panel is finished in stylish Black, high-quality surface grain on the dashboard itself, on the door linings and centre console, as well as trim strips available in different colours and materials and harmoniously interacting pearl gloss surfaces ensuring a high standard of quality and stylish elegance in both their looks and surface touch.

The central area housing the controls for the entertainment and air conditioning systems merges smoothly, with soft radii and flowing transitions into the instrument panel, finally extending down into the centre console between the front seats.

The door openers, the adjustment knobs for the air vents, the surround on the Start/Stop button, the tip bar on the ashtray, the opener on the glove compartment, the control knobs and buttons for the audio system and air conditioning as well as the trim brackets on the optional leather sports steering wheel and the Controller interacting with the optional iDrive control system are all finished in sophisticated, galvanised pearl gloss. These beautifully accentuated surfaces all enhance the high standard of quality within the BMW 1 Series Convertible.

An insert in the door lining between the upper sill-line and the armrest follows the surrounding lines in its contours and is finished in the same material as the seats. Particularly for the Convertible, the optional leather upholstery for the

seat surfaces has been expanded to include the armrests on the centre console and the doors, with ornamental trim seams rounding off this special touch of quality and style.

**Especially for BMW Convertibles:  
seat leather with Sun Reflective Technology.**

Exclusive features such as Sun Reflective Technology come straight from BMW Individual.

After having been successfully introduced in the BMW Individual 6 Series Convertible, this unique technology preventing the leather upholstery from heating up unpleasantly in the sun is now also available for all leather variants of the compact BMW 1 Series Convertible.

BMW is indeed the first carmaker in the world to use this technology in large-scale production. The particular effect of Sun Reflective Technology is provided by the integration of special colour pigments in the material serving to reflect infra-red radiation in the sunlight. This significantly reduces the temperature on the seat surfaces and armrests otherwise heated up significantly by the sun.

This effect of Sun Reflective Technology comes out particularly with dark interior colours, the pigments in Sun Reflective Technology reducing any increase in temperature caused by the sun by up to 20°C compared with conventional leather surfaces. And even with light-coloured leather, Sun Reflective Technology significantly reduces any increase in temperature caused by the sunshine. In practice, therefore, the leather seats and other surfaces are warm, but not hot, even after being exposed to intense sunshine.

## 5. Drivetrain: Power and Efficiency for Unique Driving Pleasure.



- **Prize-winning straight-six in the BMW 135i Convertible.**
- **New generation of four-cylinder gasoline and diesel engines.**
- **BMW EfficientDynamics standard on all model variants.**

The BMW 1 Series Convertible sets new standards in the compact class. Through its flair and design alone, as well as the particular experience when driving with the roof down, BMW's new Convertible leaves a lasting impression. The superior qualities of the car's drivetrain, in turn, come out clearly also on paper.

The new BMW 1 Series Convertible is available with a choice of two straight-six gasoline engines, two four-cylinder power units also running on gasoline, and one four-cylinder diesel. The top athlete in the range obviously superior to the competition is the 225 kW/306 hp BMW 135i Convertible. But the BMW 125i Convertible, the two four-cylinder gasoline engine BMW 120i Convertible and BMW 118i Convertible, as well as the BMW 120d Convertible, all offer the highest standard of performance and fuel economy in their respective class.

All of the gasoline and diesel engines available on the new BMW 1 Series Convertible ensure dynamic performance, all-round efficiency and superior refinement in typical BMW style. Developed as part of the BMW EfficientDynamics strategy, these power units come with a wide range of innovations serving to optimise both fuel consumption and emissions. The various improvements made in the interest of maximum efficiency are featured on each model according to its specific character and model features, and naturally come as standard.

A further point is that these improvements and high-tech features are not limited to the engine alone – reduction of friction forces, re-configuration of the combustion chambers, reduction of weight, optimisation of fuel/air mixture formation by means of third-generation common-rail fuel injection, VALVETRONIC or High Precision Injection in the lean burn mode, precise control of combustion and air flow – but also comprise the ancillary units and other technologies around the engine.

### **Intelligent energy management by Brake Energy Regeneration.**

Brake Energy Regeneration is one of the efficiency-enhancing technologies boasted by every BMW 1 Series Convertible. Applying a strategy of intelligent energy flow management in the car, this technology serves to concentrate the generation of electricity for the on-board network on phases of overrun and application of the brakes. As long as the engine is pulling the car, on the other hand, the alternator is generally disconnected in order to provide more drive power for that Sheer Driving Pleasure so typical of BMW.

The concept applied for such intelligent energy management can be compared with the operation of a power station using energy storage, where low-cost energy is stored during the night in reservoirs at a higher altitude and called up for consumption under peak loads during the day.

Applying this concept to Brake Energy Regeneration in the new BMW 1 Series Convertible, the intelligent system recognises the appropriate phases for storing energy, holding back electric power in the battery and then feeding it into the on-board network when required.

To maximise the service life of the battery and compensate the higher flow of energy, intelligent energy management, in conjunction with new AGM battery technology, operates with so-called regeneration cycles. In this case the battery is charged with a higher pulse voltage after certain periods of charging and discharging in order to establish appropriate phases of regeneration.

### **Auto Start Stop function shortening idling periods.**

On the manual gearbox models driven by one of the new four-cylinder engines Auto Start Stop provides greater efficiency particularly in city traffic: The system switches off the engine automatically whenever it is not required, thus reducing fuel consumption at a red traffic light, for example, to zero.

Once the driver moves the gear lever to the neutral position and takes his foot off the clutch, the electronic engine control unit switches off the engine silently and almost unnoticed. Then, to start the engine again, all the driver has to do is press the clutch pedal, the engine firing immediately without requiring any further action on the part of the driver.

### **Gearshift point indicator for highly economical motoring.**

The new BMW 1 Series Convertible offers ideal conditions for the most efficient use of fuel also when driving: The gearshift point indicator featured as standard on all manual models – an arrow symbol lighting up in the instrument cluster and specifying the optimum gear – shows the driver the ideal point

for shifting gears. To make this possible, the electronic engine “brain” determines the ideal gearshift point as a function of driving conditions and the minimisation of fuel consumption.

### **Optimised aerodynamics by active air flap control.**

Depending on the model variant, the new BMW 1 Series Convertible also features a number of additional measures helping to reduce fuel consumption without requiring any action on the part of the driver. One of these is active control of the air flaps in the radiator grille: Whenever the engine requires little or no cooling, the flaps are closed in order to noticeably improve aerodynamics and enhance fuel economy to an even higher level.

### **Electric Power Steering and on-demand control of the engine’s ancillary units.**

On-demand operation of numerous ancillary units helping to save energy enhances the efficiency of the engine to an even higher standard. EPS Electric Power Steering featured on all models with the exception of the BMW135i Convertible, for example, consumes energy only when the driver really requires steering assistance – that is only when actively moving the steering wheel. In other words, EPS Electric Power Steering does not require any energy when driving straight ahead and when taking a smooth, consistent bend without any additional movement of the steering wheel.

The new electric coolant pump on the gasoline engines is another example, operating not as a function of engine speed, but rather as a function of temperature only when really required.

This again serves to enhance engine efficiency, power uptake of approximately 200 W representing only about one-tenth of the drive energy required for a conventional pump all the time (and not just occasionally).

Yet a further example is the drive belt for the a/c compressor featuring a clutch automatically disengaging the compressor as soon as the driver switches off the air conditioning. Again, this reduces any drag force exerted by the compressor to a minimum.

### **BMW 135i Convertible: BMW’s most powerful straight-six.**

The most sporting and dynamic model in the new series is of course the BMW 135i Convertible driven by the most powerful straight-six throughout BMW’s entire range of engines – and also the most powerful engine in the compact class in general.

Combining Twin Turbo technology and High Precision Injection, this light-alloy power unit offers a unique symbiosis of high engine technology unparalleled the world over. With engine displacement of 2,979 cubic centimetres, this power unit weighing only 185 kg or 410 lb develops maximum output of 225 kW/306 hp at an engine speed of 5,800 rpm and peak torque of 400 Newton-metres/295 lb-ft throughout the very wide speed range from 1,300–5,000 rpm.

Incredible spontaneity, fascinating acceleration not just from a standstill, and seemingly inexhaustible power reserves up to maximum engine speed of approximately 7,000 rpm characterise the driving experience offered by BMW's open-air 1 Series with this engine variant. Accordingly, acceleration to 100 km/h in the BMW 135i Convertible comes in 5.6 seconds, an unparalleled figure in the car's segment and a benchmark hardly to be found anywhere even in higher segments of the market.

Top speed is limited by electronic engine control to 250 km/h or 155 mph, again raising this top-of-the-range model into the exclusive group of high-performance sports cars.

The final touch is of course provided by incomparably low fuel consumption, an average figure in the EU test cycle of just 9.4 litres/100 kilometres (equal to 30.0 mpg imp) proving that the BMW EfficientDynamics development strategy also serves to optimise fuel efficiency on an extremely powerful high-performance model.

The high level of all-round economy quite unparalleled in this performance class is ensured not only by efficiency-enhancing measures such as Brake Energy Regeneration and the gearshift point indicator, but also by Twin Turbo technology and High Precision Injection direct gasoline injection technology.

The power unit of the BMW 135i Convertible is the first and only straight-six gasoline engine in this segment to feature Twin Turbo technology serving to increase engine power and torque as a particularly efficient alternative to the enlargement of engine capacity with its significant increase in weight and fuel consumption. An additional positive effect is that the weight-optimised Twin Turbo power unit helps to improve axle load distribution and optimise the car's driving dynamics.

The combination of two turbochargers each supplying three cylinders with compressed air makes for unparalleled spontaneity in the car's reaction to the gas pedal. On the road this eliminates the turbo "gap" typical of turbocharged engines with conventional technology – the time-lag until the turbocharger builds up its power boost.

Over and above this important advantage, the engine revs up quickly and smoothly with all the power of a BMW straight-six. In its performance characteristics it is indeed comparable to a far larger normal-aspiration power unit while engine weight is much lower also thanks to the all-aluminium crankcase.

High Precision Injection plays a key role in the efficient use of fuel: This second generation of direct gasoline injection uses injectors positioned directly next to the spark plugs in the cylinder head, pumping fuel into the combustion chambers at a pressure of 200 bar.

This, in turn, allows extremely precise dosage of the fuel injected, with up to 200 injections per second. As a result, the power unit featured in the BMW 135i Convertible offers a significant edge in fuel economy versus an equally powerful turbocharged engine with intake manifold injection.

In addition to its outstanding engine power, the BMW 135i Convertible comes as standard with numerous further features giving the car its unique driving characteristics: Apart from various distinctions on the outside as part of the modified M Aerodynamics Package, these special features also include the M Sports Suspension lowering the entire car by 15 millimetres or almost 0.6", individual set-up of BMW's DSC Dynamic Stability Control, an electronically controlled locking function on the differential, a more direct control map for the Servotronic power steering geared to each model, and an even more spontaneous gas pedal control map.

**BMW 125i Convertible: alternative normal-aspiration engine in the six-cylinder league.**

The new BMW 125i Convertible also boasts a straight-six power unit within its engine compartment. In this case the normal-aspiration power unit develops maximum output of 160 kW/218 hp at 6,100 rpm from 2,996 cubic centimetres together with peak torque of 270 Newton-metres/199 lb-ft maintained consistently between 2,500 and 4,250 rpm.

This kind of power gives the BMW 125i Convertible a top speed of 238 km/h or 148 mph, with acceleration to 100 km/h in just 6.8 seconds.

Weighing only 161 kg/355 lb, this six-cylinder makes an important contribution to the harmonious balance of axle load in the BMW 125i Convertible, enhancing the car's agile driving behaviour in the process.

The unusually light weight of the engine is attributable in particular to its crankcase made up of a magnesium shell outside and an aluminium insert inside. A further point is that the cylinder head cover as well as the bedplate are also made of extremely light magnesium. And last but not least, lightweight camshafts developed specifically for this straight-six likewise serve to optimise the weight of the engine.

Consistently enhanced to an ever-increasing standard, fully-variable VALVETRONIC valve control and the on-demand electric coolant pump are further important technologies in increasing the degree of efficiency. And here again, to mention yet another point, Brake Energy Regeneration offers particularly intelligent energy management within the car.

As a result of these technologies, the BMW 125i Convertible ranks right at the top in its segment in terms of both acceleration and fuel economy. Indeed, average fuel consumption of 8.1 litres/100 kilometres, equal to 34.9 mpg imp, gives the driver the supremacy of six cylinders in a particularly economical rendition.

**BMW 120i Convertible and BMW 118i Convertible:  
four cylinders of the highest standard.**

Focusing on the four-cylinder gasoline engines for the new BMW 1 Series Convertible, BMW's engine development specialists have again opted for High Precision Injection, BMW's second-generation direct gasoline injection concept. With its capacity of 1,995 cubic centimetres, the light-alloy power unit featured in these two models is entering the market in two power stages, both engines incorporating this highly efficient direct injection technology operating in the lean burn mode.

This means that the fuel injected into the combustion chambers by piezo-injectors positioned in the middle of the cylinder head fills up the chambers in different layers varying in concentration. An ignitable fuel/air mixture with the ratio required of 1 : 14 is intentionally maintained only in the immediate vicinity of the spark plug, with the actual ratio in some cases being just 1 : 30 at the point of ignition.



Immediately after ignition, however, the combustion process expands to all the surrounding, leaner mixture layers in the combustion chamber, providing optimum power from a considerably smaller amount of fuel and with very precise fuel dosage.

The crankcase on both engine variants is made of aluminium, the biggest difference between the two engines being the use of a switching intake manifold on the more powerful drive unit.

Featuring the various improvements introduced in the context of BMW EfficientDynamics for maximum fuel economy, both four-cylinder gasoline engines in the BMW 1 Series Convertible combine outstanding acceleration and performance with equally unparalleled economy in their class.

The four-cylinder power unit in the BMW 120i Convertible develops maximum output of 125 kW/170 hp at an engine speed of 6,700 rpm, with peak torque of 210 Newton-metres/155 lb-ft at just 4,250 rpm. This ensures acceleration to 100 km/h in 8.4 seconds and gives the car a top speed of 220 km/h or 136 mph. In the EU test cycle, finally, the BMW 120i Convertible requires an average of just 6.6 litres/100 kilometres, equal to 42.8 mpg imp. The CO<sub>2</sub> rating is 158 grams/kilometre.

Developing maximum output of 105 kW/143 hp at 6,000 rpm and peak torque of 190 Newton-metres/140 lb-ft at 4,250 rpm, the second four-cylinder likewise offers everything it takes for sporting performance: Top speed of the BMW 118i Convertible is 210 km/h or 130 mph, with acceleration to 100 km/h in 9.3 seconds. Average fuel consumption in the EU test cycle is 6.3 litres/100 kilometres (equal to 44.8 mpg imp), and the CO<sub>2</sub> emission rating is 149 grams per kilometre.

**BMW 120d Convertible: particulates filter featured as standard.**

Displacing 1,995 cubic centimetres, the four-cylinder turbodiesel featured in the new BMW 120d Convertible develops 130 kW/177 hp at 4,000 rpm, with peak torque of 350 Newton-metres/258 lb-ft maintained consistently between 1,750 and 3,000 rpm.

Top speed of 222 km/h or 138 mph, acceleration to 100 km/h in 8.1 seconds, and average fuel consumption of 5.1 litres/100 kilometres (equal to 55.4 mpg imp) make the new BMW 120d Convertible a wonderful symbiosis of sporting performance and supreme economy.

Compared with other models in its class, the diesel version of the 1 Series Convertible again ranks right at the top in terms of acceleration and fuel economy, offering an equally good CO<sub>2</sub> emission rating of just 134 grams/kilometre.

The power unit of the new BMW 120d Convertible boasts an exhaust gas turbocharger featuring variable turbine geometry to provide a smooth balance of power and torque throughout the entire load range. Diesel fuel is injected by third-generation common-rail direct gasoline injection using piezo-injectors operating at a pressure of 1,800 bar.

The BMW 120d Convertible also features the wide range of BMW Efficient-Dynamics technologies as standard, including Brake Energy Regeneration, Auto Start Stop, a gearshift point indicator, and active air flap control. As a representative of the latest generation of diesel engines, the power unit furthermore comes as standard with a diesel particulates filter positioned close up to the engine itself and therefore optimising all emissions, not just CO<sub>2</sub>.

As a result of modern power and performance characteristics as well as improved sound insulation on modern diesel engines, the difference between diesel and gasoline technology is hardly noticeable any more to the less experienced driver or to the driver not so used to the car – for example in the case of a rental vehicle. Precisely this is why the new BMW 120d Convertible comes with a tank filler safety guard allowing exclusive use of only a diesel filler pump at the filling station. This is a lock ratchet designed for only a standardised diesel pump to fit in.

### **Automatic transmission with Steptronic function.**

As an alternative to the manual gearbox, all engine variants in the new BMW 1 Series Convertible may be combined as an option with six-speed automatic transmission. With its special converter technology, the automatic transmission reduces both energy losses as well as reaction and gearshift times – and being connected directly to the engine, the transmission enhances the dynamic character of the car as well as the precise choice of gears, allowing the driver to shift down quickly by one or even two gears whenever the driver, kicking down the gas pedal, expresses his wish for particularly dynamic acceleration.

The Steptronic function enables the driver to shift gears manually on the automatic transmission either via the selector lever in the centre console or via paddles on the steering wheel. Such paddles are standard on the BMW 135i Convertible with automatic transmission and come as an option on the automatic transmission version of the BMW 125i Convertible.

Regardless of its current operating mode, the automatic transmission in the BMW 1 Series Convertible offers that sports driving feeling so typical of a BMW. Shifting to manual gear selection in the BMW 135i Convertible, for example, the driver will enjoy a particularly sporting set-up of the transmission enhancing the car's dynamic acceleration to an even higher level.

The driver will also feel and greatly enjoy the extremely short gearshift times every time the transmission shifts gears, spontaneous movement of the indicator needle in the rev counter providing further proof of the car's particularly powerful and dynamic acceleration.

## 6. Suspension and Driver Assistance Systems: Dynamics, Comfort and Safety Tailored to the Driver.



- **Rear-wheel drive as the foundation for sporting driving characteristics.**
- **Model-specific stability control featured as standard, Active Steering optional.**
- **BMW 135i Convertible fitted as standard with M Sports Suspension and an electronically controlled locking function on the differential.**

High-torque and fast-revving power units deliver the power, the rear wheels then transmit this superior muscle to the road. Precisely this drive principle characterises the BMW 1 Series Convertible as a genuine BMW.

To ensure unmistakable driving pleasure, another indispensable prerequisite is particularly demanding chassis and suspension technology – which is precisely why the BMW 1 Series Convertible comes with one of the most sophisticated high-tech suspension systems in its segment.

A further point is perfectly balanced axle load distribution of almost 50 : 50 front-to-rear, plus the optimum seating position of the driver near the car's centre of gravity as the ideal set-up for agile handling. And last but not least, the dynamic driving potential of the BMW 1 Series Convertible becomes the ultimate experience through a number of sophisticated driver assistance systems in some cases exclusive to BMW.

### **Unparalleled:**

#### **high-tech construction principles on the front and rear axles.**

The level of construction technology on the axles exceeds all standards in the compact segment: At the rear the BMW 1 Series Convertible features a newly developed five-arm rear axle in steel structure carefully tailored to the specific requirements of the extra-powerful and high-torque engines.

The result is extremely precise wheel guidance and an increase in rear wheel track versus the three- and five-door models in the BMW 1 Series by 20 millimetres or 0.79". An anti-roll bar serves furthermore to reduce body sway in fast bends and the overall set-up of the rear axle is designed for supreme agility and optimum sound insulation.

The final drive on the new BMW 1 Series Convertible has been optimised for smooth running characteristics at all times. Double-helical ball bearings serve to reduce the operating temperature nevertheless reaching the ideal level more quickly thanks to the smaller amount of fluid in the final drive housing. Both of these features help to enhance both functionality and the service life of the rear axle differential, and at the same time the new final drive ensures a further reduction of fuel consumption.

At the front the BMW 1 Series Convertible comes with a double-joint spring strut tiebar axle again quite unique in the compact segment. The anti-roll bar on the axle made largely of aluminium is designed as a hollow tube providing an optimum synthesis of superior stiffness and low weight – together with the outstanding stability of track control arms and thrust rods as well as the exact wheel guidance a further contribution to the car's driving dynamics.

**Set-up in sporting style and 15 millimetres lower: the M Sports Suspension featured as standard on the BMW 135i Convertible.**

Both the chassis springs optimised for tension and weight and the twin-sleeve gas pressure shock absorbers are tailored to the specific power and performance data of the individual engine variants. And as the top model in the range, the new BMW 135i Convertible comes as standard with an M Sports Suspension lowering the entire body by 15 millimetres or almost 0.6" – a suspension also available as an option on the other engine variants.

In practice the M Sports Suspension not only fulfils the demands of the sports-minded driver, but is also sufficiently comfortable to make long journeys and everyday traffic a truly pleasant driving experience.

**EPS Electric Power Steering for greater precision and lower energy consumption, Active Steering as an option.**

EPS Electric Power Steering with its integrated Servotronic function for speed-related steering assistance is an important new development. EPS enhances both precision and comfort in the steering process and reduces fuel consumption at the same time. For contrary to conventional mechanical-hydraulic systems, steering assistance in this case is provided by an electric motor only activated when such assistance is really required or desired by the driver.

As an option, the BMW 1 Series Convertible is available with the world's only Active Steering for even greater precision and steering comfort. While Servotronic, the technology featured as standard, influences the steering effort

required, Active Steering varies the steering transmission ratio as a function of road speed: With the same movement of the steering wheel, the driver obtains a larger steering lock at low speeds than at high speeds.

In practice, this facilitates the process of parking by reducing the effort and steering forces required. At high speeds, on the other hand, Active Steering facilitates the precise maintenance of the desired direction, keeping the car smoothly and reliably on track.

Movement of the steering wheel is conveyed to the front wheels in this case by an add-on transmission integrated in the steering column. The steering angle determined by the driver is thus varied to a greater or lesser extent, depending on road speed, by means of an electric motor and a planetary gearing.

### **Dynamic driving programs for perfect control of the car.**

The new BMW 1 Series Convertible comes as standard not only with ABS anti-lock brakes, but also with DSC Dynamic Stability Control preventing the rear end of the car in a critical situation from serving round (oversteer) or the front end “pushing” out of a bend over the front wheels (understeer) by applying the brakes specifically on individual wheels and reducing engine power accordingly.

The effect and operation of Dynamic Stability Control is tailored to the dynamic driving potential of the BMW 1 Series Convertible. Interacting with optional Active Steering, DSC is furthermore able, by applying an appropriate counter-steering effect, to prevent the car from swerving out of control when braking on surfaces with a varying frictional coefficient left to right – for example a dry surface on the left and wet asphalt on the right (modal split).

DSC also encompasses ASC Automatic Stability Control preventing an individual drive wheel from spinning when setting off, CBC Cornering Brake Control stabilising the car if necessary when applying the brakes in a bend, and DTC Dynamic Traction Control serving, when required, to optimise the car's traction and wheel grip.

Changing the basic set-up whenever necessary, DTC allows greater slip on the drive wheels, enabling the driver, for example, to set off smoothly in deep snow with the wheels intentionally spinning slightly. In addition, DTC allows even faster and more intense lateral acceleration all the way to a controlled power slide.

On the new BMW 1 Series Convertible DSC Dynamic Stability Control may be fully deactivated simply at the touch of a button.

DSC in the new BMW 135i Convertible comprises a number of extended functions. These include the Start-Off Assistant preventing the car from rolling back when setting off on an uphill gradient and automatic Fading Compensation preventing the fading effect on extremely hot brakes.

Pre-loading of the brake pads in situations indicating that the driver will have to apply the brakes very hard after suddenly letting go of the gas pedal ensures an enhanced brake standby function. And the Dry Braking function, finally, improves the effect of the brakes in the wet by regularly applying the brake pads to the discs slightly in order to remove the film of water otherwise building up on the discs.

**Differential with electronically controlled locking function for improved traction in the BMW 135i Convertible.**

To ensure optimum traction also with high power and superior torque, the new BMW 135i Convertible comes with special traction-enhancing technology.

The main purpose of these improvements is to support the driver in a sporting and ambitious style of motoring, for example when accelerating out of a bend and hairpin. An electronically controlled locking function on the differential thus provides optimum traction in such a case in the DSC-off mode, that is with DSC completely switched off.

In this case the brakes are applied specifically and appropriately on a drive wheel spinning in a tight bend, conveying any superfluous power to the other drive wheel on the opposite side. This improves the car's traction and pulling force without any negative influence on the car's steering behaviour.

A further point is that DSC comes with an integrated brake pad wear indicator on all variants of the BMW 1 Series Convertible. To provide this function the electronic monitor forming part of CBS Condition Based Service calculates the distance remaining before the brake pads have to be replaced.

The BMW 120i Convertible, the BMW 118i Convertible and the BMW 120d Convertible all come on 16-inch wheels, while the two six-cylinder models run as standard on 17-inch light-alloy wheels. A further point is that the BMW 135i Convertible features not only an M Sports Suspension as standard, but also high-performance brakes made up of six-piston fixed callipers on the front axle and two-piston fixed callipers on the rear, finished in exclusive grey paintwork and proudly bearing the letters "BMW" in white.

The ASC and DSC Dynamic Stability Control driving stability systems are also set up individually for each model, taking the particular sporting character of the BMW 135i Convertible into account. And last but not least, the top-of-the-range 1 Series Convertible comes with a modified gas pedal control map to give the engine an even more spontaneous reaction.

**Runflat tyres and Tyre Defect Indicator featured as standard.**

All versions of the new BMW 1 Series Convertible come on runflat tyres enabling the driver to go on even after an abrupt loss of tyre pressure: Thanks to these tyres, the driver can continue after a puncture at a speed of up to 80 km/h or 50 mph for at least 150 kilometres or 90 miles, even on a completely flat tyre.

A Tyre Defect Indicator also comes as standard, permanently monitoring air pressure in all tyres and warning the driver through a signal in the instrument cluster as soon as air pressure drops more than 30 per cent below the ideal level.



## 7. Body and Safety: Dependable Concept for Optimum Protection in Every Situation.



- **Bodyshell with extreme torsional stiffness.**
- **Frontal and side airbags, crash-optimised front seats.**
- **Rollover sensors and rollbars moving up automatically.**

In developing a convertible the optimisation of occupant safety always presents particular challenges. First and foremost, of course, the function of a fixed roof in enhancing body stiffness and giving the passenger compartment appropriate stability must be replaced as efficiently as possible, without any negative repercussions on the weight and driving dynamics of the vehicle.

The BMW 1 Series Convertible comes from the start with ideal conditions for a truly outstanding safety concept convincing in every respect. This is ensured by the stable structure of the body of the BMW 1 Series, with BMW's particular skill in developing very dynamic and safe convertibles making a further contribution.

Conducting precise calculations and applying a wide range of virtual simulation, the load-bearing concept of the car especially around the floorpan and on the side frame was tailored from the start to the particular requirements of the BMW 1 Series Convertible. High-strength steel, additional reinforcement and special deformation elements ensure that even in the event of a severe collision the body of the car absorbs a vast majority of the impact energy, diverting this energy along defined load paths and thus keeping it away from the passenger cell.

In a collision from the side, for example, the floorpan diverts impact forces to the side of the car facing away from the impact, with the crash-resistant doors and the instrument panel between the A-pillars contributing to the car's lateral stability.

Further reinforcement is provided by longitudinal load-bearing profiles along the luggage compartment and rear side panels integrated in the side frame, again to withstand asymmetric loads and forces.

Both crash safety and driving dynamics benefit from the exceptional torsional stiffness of the bodyshell. Indeed, the BMW 1 Series Convertible offers a standard in this respect clearly oriented towards the supreme level of the BMW 3 Series Convertible with its outstanding driving dynamics and

superior all-round safety. So it is not surprising that the new BMW 1 Series Convertible fulfils all legal requirements for active and passive safety applicable in automobile markets the world over – and at the same time the car offers all the assets required for good results in all crash tests relevant worldwide.

**Just in case: airbags, rollbars, crash-optimised front seats.**

Within the interior a number of restraint systems carefully harmonised with one another and masterminded by a central electronic safety “brain” ensure maximum occupant safety on all four seats.

Four airbags for the occupants in the new BMW 1 Series Convertible naturally come as standard to provide optimum protection right from the start. Inflating in two stages, the frontal airbags provide exactly the right restraint required in each case, depending on the intensity of an impact.

Side airbags integrated in the front seat backrests inflate in a collision from the side all the way up to head level, reducing the risk of injury around the hips, chest and head.

The new BMW 1 Series Convertible comes as standard with crash-optimised front seats, specially padded headrests and backrests significantly reducing the occupants’ risk of injury in an impact from the rear.

All seats feature three-point inertia-reel seat belts and headrests. The belt pivots are mounted inside on the frame of the driver’s and front passenger’s seats and are fitted firmly to the body of the car on the outside.

The rear seats come as standard with ISOFIX fastenings for child seats, the foot pedals giving way to the front in the event of a head-on collision as well as the footrest giving in under load serving additionally to reduce the risk of foot injury for the driver.

**Rollover sensors and extremely strong A-pillars.**

The new BMW 1 Series Convertible also comes with rollover sensors permanently monitoring vertical and horizontal movements of the car. As soon as the safety electronics register the risk of a rollover, two rollbars normally hidden behind the headrests at the rear move up within fractions of a second and the belt latch tensioners for the front seats as well as the head-thorax airbags at the side are activated.

As yet a further precaution for the event of a rollover, stability of the A-pillar and the windscreen frame has been optimised to a greatly enhanced level of all-round safety.

Over and above passive safety, active safety is also far better than average in the BMW 1 Series Convertible. Indeed, the car offers features quite unique in the compact segment not only in terms of its suspension and driver assistance systems, but also in its lights and illumination.

As an example, bi-xenon headlights available as an option and Adaptive Headlights including Bending Lights make driving in the dark even safer, particularly in town and on country roads. The Bending Lights incorporate two additional spotlight sources in the two inner headlight units turning to the side whenever required.

The combination of these comfort and safety functions in the market segment of the BMW 1 Series Convertible is quite unique.

Daytime driving lights incorporating two corona rings in each headlight unit in typical BMW style improve visibility of the vehicle under normal and dusky light conditions. And last but not least, two-stage brake lights varying according to the brake pressure applied give motorists following from behind a particularly clear and effective warning whenever the driver has to brake hard in an emergency.

## 8. Features and Equipment: Fun with Style and Premium Quality.



- **Wide range of customisation thanks to a large choice of different colours and trim options.**
- **USB plug for integration of an Apple iPod.**
- **Innovative rear rack system made of aluminium.**

The BMW 1 Series Convertible offers premium qualities also in its features and equipment so far to be admired only in upmarket convertibles. The car's standard features include numerous sophisticated refinements in the interior with galvanised, softly shimmering pearl gloss surfaces, the steering column adjustable for height and reach, height-adjustable seats for the driver and front passenger, ISOFIX fastenings on the child seats at the rear, electric window lifts front and rear, as well as central locking with remote control and a self-charging key.

The soft top on the BMW 1 Series Convertible opens and closes electrohydraulically on all model variants. It is activated either by pressing a button or by remote control and comes with electric rear window heating automatically switching off when not required.

Optionally available bi-xenon headlights in ellipsoid technology and Adaptive Headlights including Bending Lights also available as an option offer supreme comfort and optimum driving safety in the BMW 1 Series Convertible at night.

The daytime light function provided in typical BMW style by two corona rings on each headlight unit enhances visibility of the car under normal and dusky light conditions.

The BMW 1 Series Convertible may also be fitted with a rain sensor automatically activating and operating the windscreen wipers as a function of rain intensity.

The rain sensor even interacts with automatic headlight control masterminding the low-beam headlights as a function of ambient brightness, switching on the low beams when required both in the dusk and when driving through a tunnel without requiring any action on the part of the driver.

**Exclusive colour and trim variants providing an individual touch.**

The BMW 1 Series Convertible makes motoring a truly colourful experience, offering all kinds of customisation options. Apart from three roof and twelve paintwork colours, the customer also has the choice of three interior world colours, numerous variants and colours for the upholstery and equipment, as well as six different trim options.

The seats are available in two cloth options, one cloth/leather combination, and one all-leather option – to a certain extent with special features and details specifically created for the BMW 1 Series Convertible.

The Pearlpoint cloth/leather combination is also available in Beige on the Convertible, with Boston leather coming also in Coral Red and Savannah Beige. And to match the exclusive Cashmere Silver paintwork colour, there is also interior trim in Cashmere Silver.

**MP3-compatible CD player featured as standard, complete iPod integration as an option.**

The audio systems available on the new BMW 1 Series Convertible are among the most sophisticated high-tech units to be found in the compact segment.

Fitted as standard, the CD player is also able to play music files in MP3 format. A USB plug, in turn, comes as an option to supplement the AUX-in connection featured as standard, serving to connect various external MP3 players or other data media such as a conventional USB stick integrated into the car's audio system.

Over and above these many features, the BMW 1 Series Convertible may also be equipped with a special interface tailored to the Apple iPod.

The many entertainment features enhanced and upgraded in this way are masterminded via the controls for the audio system or, for even greater comfort, via the iDrive controls featured on the BMW 1 Series Convertible in conjunction with an optional navigation system.

This also includes a reliable supply of power to the Apple iPod via the car's on-board network, with the functions of an external music player also being operated very reliably by the Controller housed in the centre console.

On models equipped with an optional armrest and a USB interface, there is also a practical bag serving to accommodate an external MP3 player.

**Truly exceptional in a convertible:  
M Sports Package as an option straight from the factory.**

The BMW 135i Convertible comes as standard with an M Aerodynamics Package specially modified for this very special car. All other model variants, in turn, may be upgraded in their looks and technical features as an option with various components from BMW M GmbH.

The M Sports Package for the BMW 1 Series Convertible comprises aerodynamically optimised covers on the front and rear bumpers including foglamps and special side-sills. And Le Mans Blue Metallic comes as a special body colour exclusive to models with the M Sports Package.

The sports seats in the M Sports Package are finished in a combination of Sensatec cloth or, as an option, in leather.

The range of features from BMW M GmbH for the new BMW 1 Series Convertible also includes door entry trim complete with the M logo, the M leather steering wheel and an M footrest for the driver's left foot. The gaiters on the gearshift lever and handbrake, as well as the handbrake handle, are finished in soft nappa leather, and the wide range of interior features is rounded off by trim strips in Glacier Silver aluminium highlighting the sporting character of the cockpit.

The broad choice of BMW M GmbH products for the new BMW 1 Series Convertible also comprises light-alloy wheels in two different M designs and with tyres varying in size front-to-rear. As an alternative to the regular 17-inch wheels, the driver also has the choice of 18-inch light-alloy rims exclusively in combination with the M Sports Package. Clearly, these wheels highlight the character of the new BMW 1 Series Convertible as by far the most sporting model in its segment.

**Unbeatable: wide range of transport options.**

With the roof open, the new BMW 1 Series Convertible offers luggage compartment capacity of 260 litres or 9.1 cu ft. Closing the soft top and opening up the variable cover between the roof and luggage compartment, the driver is then able to increase storage capacity to 305 litres or 10.7 cubic feet.

Benefiting from the rear seat backrest developed exclusively for the BMW 1 Series Convertible, this two-door performer offers an even higher standard of function, optional through-loading to the rear interacting with the transport bag included in this case offering lots of space for bulky objects.

The through-loading is higher and wider than all conventional systems of this kind, accommodating two snowboards within the transport bag. A further option is to load the car with two full-size golf bags – if one of the golf bags is placed within the transport bag, the second will fit conveniently crosswise in the luggage compartment. A zipper opening, finally, provides access from the rear to any items stored within the transport bag.

**Patented lightweight rear rack with rapid closing and fastening system.**

Equipped with a luggage rack, the new BMW 1 Series Convertible – with the exception of the BMW 135i Convertible – is able to handle even more challenging transport requirements. Available as an Original BMW Accessory, the rear luggage rack is fastened to the rear end of the car, serving to safely transport, say, two bicycles, two snowboards or two pairs of skis. Made of aluminium, the rear rack fits on to the car by means of a patented rapid fastening system incorporating two mounting points in the rear bumper and available as an option straight from the factory, without any tools being required for this purpose.

Again in the interest of extra convenience, the rear rack may be swivelled to the side smoothly and easily, whether loaded or unloaded. This allows the driver to load and unload the luggage compartment easily and ergonomically, without having to remove the rear rack first.

**Unique: BMW Online, BMW Assist and BMW TeleServices.**

Through the Controller positioned in the middle of the instrument panel, the iDrive control system enables the user – as an option even through voice entry – to mastermind all secondary and comfort functions in the Communication, Air Conditioning, Entertainment and Navigation modes easily and conveniently.

The iDrive system also features individually programmable favourite buttons for direct retrieval of functions used particularly often, such as frequent destinations in the navigation system, radio stations or telephone numbers. The sensors incorporated in each button display the function required in the folding TFT screen on the instrument panel right from the start in response to slight surface touch, without the user being required to actually press the button. Hence, the driver is able to choose the respective function conveniently and safely, while keeping his eyes firmly on the road.

In conjunction with iDrive control and a navigation system including mobile phone preparation complete with a Bluetooth interface, the BMW 1 Series Convertible is also available with the mobile BMW Online internet portal and the BMW Assist telematics service.

Drivers of cars equipped with these features are able to use the wide range of BMW TeleServices free of charge, extending from an Automatic Teleservice Call via Manual Teleservice Call all the way to BMW Teleservice Diagnosis including Teleservice Assistance.

When placing an Automatic Teleservice Call, the car automatically determines the type of service required and when it is needed, using the on-board Condition Based Service (CBS) diagnostic system for this purpose. To coordinate a visit to the workshop well in advance, data on the current condition of the engine oil, brake fluid, the brake discs and pads as well as other parts subject to wear and tear can be transmitted to the customer's BMW Service Partner by a telephone connection.

In the event of deficiencies in the car's electronic systems, BMW Teleservice Diagnosis serves to transmit defect codes stored by the system to BMW Breakdown Assistance. And if the cause of a problem may be remedied by re-setting the software on the respect control unit, there is even the option to transmit an appropriate command directly to the car from the BMW Breakdown Assistance Centre.

On models not delivered with a navigation system and BMW iDrive, an additional, illuminated storage box may be provided as an option in the middle of the instrument panel. A further option in this case is to provide cupholders in the centre console behind the gearshift or gear selector lever. And as a supplementary or alternative feature over and above these cupholders, a further, add-on cupholder is available as an option for the centre console.



## 9. Production: Flexible, Efficient and Environmentally Conscious.



- **Production of the BMW 3 and 1 Series at BMW Plant Leipzig.**
- **Production on-demand of up to 700 units a day.**
- **BMW Plant Leipzig: high standard of environmental protection and quality assurance.**

Like the BMW 1 Series Coupé and the three-door version of the BMW 1 Series Hatch, the new BMW 1 Series Convertible is built exclusively at BMW Plant Leipzig for the world market.

This means that just three years after starting operation, BMW Plant Leipzig builds not only the BMW 3 Series Saloon, but now also three models within the BMW 1 Series. Through this modern car production plant BMW is indeed expressing its great commitment as a premium manufacturer to ongoing production in Germany. Highly flexible production and job structures in Leipzig ensure that production meets the greatest demands and challenges.

One of the special strengths of BMW Plant Leipzig was the ability to conduct all the preparations for starting production of the new BMW 1 Series Convertible in the Bodyshop, in the Paintshop and in Assembly while continuing production as usual. This was made possible, to mention just one factor, by the unique “comb” structure of the Assembly Hall creating appropriate conditions for flexibly extending individual “fingers” in the building in order to integrate additional operations and steps in production with minimum effort.

In the process of building and completing the bodyshells in both the Paintshop and in Assembly, the BMW 3 Series Saloon and the three versions of the BMW 1 Series – the three-door, Coupé, and Convertible – are built on the same lines. Components for the various models are produced in separate areas – when required – only in the Bodyshop. This provides flexible production capacities for optimum use as a function of market requirements.

### **Individual production, integrated assembly: the soft top for the BMW 1 Series Convertible.**

The roof system for the BMW 1 Series Convertible is delivered just-in-time to the assembly line in accordance with the customer’s specific demands and wishes. Then, following final production, each BMW 1 Series Convertible

built at the Leipzig Plant goes through a thorough examination process highlighting a roof test to make sure that the soft top is absolutely tight. Inter alia, this includes a ten-minute shower test.

### **Central building winning an architects' award.**

BMW Plant Leipzig is located in an industrial estate in the north of the Saxon city and involved an investment of approximately Euro 1.3 billion. On the overall premises of approximately 208 hectares, the buildings cover an area of some 44 hectares.

Direct connection to the Autobahn helps to keep the surrounding towns and villages free of the approximately 350 trucks driving to and from the Plant every day. A further point is that the cars built are transported from the Plant also by train, with BMW Plant Leipzig being connected directly to the railway network.

The production buildings are spaced out around the Central Office, Service and Communication Complex, the Central Building designed by renowned architect Zaha Hadid. This unique building provides short and direct connections between the production areas and offers ample space for encounters and communication. Acknowledging its unique design, the building was awarded the Architects' Prize of the City of Leipzig and the renowned German Architects' Prize, to mention just two examples, in 2005.

Series production of the BMW 3 Series Saloon in Leipzig started on 1 March 2005, with production of the three-door version of the BMW 1 Series being taken up just two years later as the integration of an additional model. Production of the BMW 1 Series Coupé in Leipzig then began in September 2007. The 100,000th BMW built in Leipzig came off the production line on 16 June 2006, with the 250,000th car following on 3 July 2007.

Flexible working time models and shift systems allow BMW Plant Leipzig to currently build some 650–700 cars a day, depending on demand and requirements in the market. This is made possible by BMW's "Formula for Work" allowing plant operating periods between 60 and 140 hours a week and providing the option to adjust at short notice to different production requirements with only a small investment.

**5,300 jobs jointly created by BMW and external suppliers.**

BMW Plant Leipzig is a fully-fledged production plant with an integrated Supply Centre for external suppliers. This ensures that the parts supplied as well as pre-assembled components reach the production lines as quickly and directly as possible. So far some 5,300 jobs have been created on the premises as a whole, among them about 2,500 directly in the BMW Plant.

The Plant's Logistics Service moves about 10,000 cubic metres of material a day. Approximately 80 per cent of the parts reach production just in time, that is exactly when needed, and just in sequence, that is in the right order for the assembly process.

A driver-less transport system for stock parts and components reduces the cost of transport within the Plant and ensures a stable assembly process.

The car bodysHELLS and the painted bodies are transported on specially built conveyer belts measuring 600 metres in length through the Central Building several times, eliminating the traditional separation of administration and production and offering associates in administration a direct and immediate view of the production process.

The upcoming expansion of BMW Plant Leipzig will serve to further enhance the efficiency of the production process and optimise the Plant's logistics. A new Press Shop producing a wider range of components will be completed by the end of 2009 at a cost of approximately Euro 100 million, producing doors, front and rear lids so far largely supplied by other BMW plants. This Press Shop will supplement the existing Bodyshop in Leipzig in a most appropriate manner, once again increasing the number of jobs by approximately 150 new positions.

**Plant Leipzig as part of BMW's worldwide production network.**

As an ultra-modern production facility, BMW Plant Leipzig uses particularly clean production processes serving to spare the environment. The Paintshop, for example, operates entirely with water-based paint and environmentally compatible clear powder paint. Integrated heat recirculation, in turn, helps to preserve valuable resources and enhance the standard of economy in production.

Quality control plays a fundamental role in the production process at BMW Plant Leipzig. Like all production facilities within the BMW Group, Plant Leipzig follows the highest standards of quality for all products

manufactured and services rendered. The structures of the Plant, its technical equipment and the qualification of employees are geared consistently to the production of premium products.

To maintain a high standard of quality on all cars built, all models are consistently checked and monitored during the entire production process. In addition, individual models are selected from time to time for the most precise detailed inspections focusing on quality features relevant to the customer. And last but not least, the efficiency of all processes within the plant as well as the interfaces to external partners are systematically verified and improved at regular intervals.

BMW Plant Leipzig is part of BMW' worldwide production network comprising no less than 23 facilities in 12 countries. In addition, BMW Plant Leipzig is a member of the East German Automotive Cluster covering the concentration of car companies and institutions in the new German Länder in the east. The quest of the East German Automotive Cluster is to give the automobile industry in the east of Germany its own distinctive profile, promoting and expanding skills and competences and thus helping to ensure long-term and lasting development within the entire region.

# 10. Specifications

## BMW 1 Series Convertible.

### BMW 118i, 120i, 125i, 135i.



		BMW 118i	BMW 120i	BMW 125i	BMW 135i
<b>Body</b>					
No of door/seats		2/4	2/4	2/4	2/4
Length/width/height (unladen)	mm	4,360/1,748/1,411	4,360/1,748/1,411	4,360/1,748/1,411	4,360/1,748/1,411
Wheelbase	mm	2,660	2,660	2,660	2,660
Track, front/rear	mm	1,484/1,517	1,480/1,513	1,474/1,507	1,474/1,507
Ground clearance	mm	140	140	140	140
Turning circle	m	10.7	10.7	10.7	10.7
Tank capacity	app ltr	53	53	53	53
Cooling system incl heater	ltr	8.4 (9.2 <sup>1</sup> )	8.4(9.2)	8.2 (8.5)	8.2 (8.5)
Engine oil	ltr	4.25	4.25	6.5	6.5
Transmission fluid	ltr	Lifetime	Lifetime	Lifetime	Lifetime
Final drive fluid	ltr	Lifetime	Lifetime	Lifetime	Lifetime
Weight, unladen, to EU <sup>2</sup>	kg	1,480 (1,505)	1,505 (1,535)	1,585 (1,615)	1,675 (1,685)
Max load to DIN	kg	440	440	440	440
Max permissible	kg	1,845 (1,870)	1,870 (1,900)	1,950 (1,980)	2,040 (2,050)
Max axle load, front/rear	kg	845/1,065	870/1,070	910/1,095	960/1,115
Max trailer load <sup>3</sup>					
Braked (12%/unbraked)	kg	1,200/670	1,200/680	1,200/700	–
Max roofload/max towbar download	kg	–	–	–	–
Luggage compartment ISO 3832	ltr	260–305	260–305	260–305	260–305
Air drag	C <sub>d</sub> x A	0.32 x 2.09	0.32 x 2.09	0.33 x 2.09	0.34 x 2.09
<b>Power Unit</b>					
Config/No of cyls/valves		Straight/4/4	Straight/4/4	Straight/6/4	Straight/6/4
Engine management		MSD 80.2	MSD 80.2	MSV80	MSD80
Capacity, effective	cc	1,995	1,995	2,996	2,979
Bore/stroke	mm	90/84	90/84	88/85	89.6/84.0
Compression ratio	:1	12.0	12.0	10.7	10.2
Fuel grade		RON 91–98	RON 91–98	RON 91–98	RON 95–98
Max output	kW/hp	105/143	125/170	160/218	225/306
at	rpm	6,000	6,700	6,100	5,800
Max torque	Nm/lb-ft	190/140	210/155	270/199	400/295
at	rpm	4,250	4,250	2,500–4,250	1,300–5,000
<b>Electrical System</b>					
Battery/installation	Ah/–	90 (70)/lug comp	90 (70)/lug comp	70/lug comp	80/lug comp
Alternator	A/W	180/2,520	180/2,520	180/2,520	180/2,520
<b>Chassis and Suspension</b>					
Suspension, front		Double-joint tiebar spring strut axle, aluminium			
Suspension, rear		Five-arm axle, lightweight steel			
Brakes, front		Single-piston swing-calliper disc bakes			Six-piston fixed-calliper
Diameter	mm	Vented/292 x 22	Vented/300 x 24	Vented/300 x 24	Vented/338 x 26
Brakes, rear		Single-piston swing-calliper disc bakes			Two-piston fixed-calliper
Diameter	mm	Vented/300 x 20	Vented/300 x 20	Vented/300 x 20	Vented/324 x 22
Driving stability systems		ABS, CBC, ASC, DSC, DTC, DBC			
Steering		Rack-and-pinion steering; 3.0 turns; EPS Electric Power Steering			
Steering transmission ratio,	:1	16.0	16.0	16.0	16.0
Gearbox		Six-speed manual (optional six-speed automatic)			
Gear ratios I	:1	4.323 (4.171)	4.323 (4.171)	4.323 (4.065)	4.055 (4.171)
II	:1	2.456 (2.340)	2.456 (2.340)	2.456 (2.371)	2.396 (2.340)
III	:1	1.659 (1.521)	1.659 (1.521)	1.659 (1.551)	1.582 (1.521)
IV	:1	1.230 (1.143)	1.230 (1.143)	1.230 (1.157)	1.192 (1.143)
V	:1	1.000 (0.867)	1.000 (0.867)	1.000 (0.853)	1.000 (0.867)
VI	:1	0.848 (0.691)	0.848 (0.691)	0.848 (0.674)	0.872 (0.691)
R	:1	3.938 (3.403)	3.938 (3.401)	3.938 (3.200)	3.677 (3.403)
Final drive ratio	:1	3.45 (3.91)	3.73 (4.1)	3.23 (3.73)	3.08 (3.46)
Tyres, front		195/55 R16 87H RSC	205/55 R16 91V RSC	205/50 R17 89W RSC	205/50 R17 89W RSC
Tyres, rear		195/55 R16 87H RSC	205/55 R16 91V RSC	205/50 R17 89W RSC	225/45 R17 91W RSC
Rims, front		6.5J x 16 steel	7J x 16 steel	7J x 17 LA	7J x 17 LA
Rims, rear		6.5J x 16 steel	7J x 16 steel	7J x 17 LA	7.5J x 17 LA

		<b>BMW 118i</b>	<b>BMW 120i</b>	<b>BMW 125i</b>	<b>BMW 135i</b>
<b>Performance</b>					
Power-to-weight ratio, DIN	kg/kW	13.4 (13.6)	11.4 (11.7)	9.4 (9.6)	7.1 (7.2)
Output per litre	kW/hp	52.6/71.5	62.7/85.3	53.4/72.6	75.5/102.7
Acceleration 0–100 km/h	sec	9.3 (10.1)	8.4 (9.0)	6.8 (7.4)	5.6 (5.7)
0–1000 m	sec	30.6 (31.1)	29.3 (29.7)	27.6 (28.1)	25.0 (25.1)
80–120 km/h in 4th/5th gear	sec	9.6/12.5 (-)	8.2/10.6 (-)	7.3/9.2 (-)	5.5/6.5 (-)
Top speed	Km/h	210 (208)	220 (218)	238 (236)	250 (250)
<b>Fuel Consumption in EU Cycle</b>					
Urban	ltr/100 km	8.5 (8.7)	8.9 (9.1)	11.7 (11.6)	13.3 (13.5)
Extra-urban	ltr/100 km	5.0 (5.4)	5.2 (5.5)	6.0 (6.1)	7.1 (7.0)
Composite	ltr/100 km	6.3 (6.6)	6.6 (6.8)	8.1	9.4
CO <sub>2</sub>	g/km	149 (158)	158 (163)	195	224 (225)
<b>Miscellaneous</b>					
Emission rating		EU4	EU4	EU4	EU4
		-	-	-	-

<sup>1)</sup> Figures in brackets apply to models with automatic transmission.

<sup>3)</sup> May be increased under certain conditions.

<sup>2)</sup> Weight of vehicle in road trim (DIN), plus 75 kg for driver and luggage.

<sup>4)</sup> Data not yet available at time of print.

# BMW 120d.

## BMW 120d

### Body

No of door/seats		2/4
Length/width/height (unladen)	mm	4,360/1,748/1,411
Wheelbase	mm	2,660
Track, front/rear	mm	1,480/1,513
Ground clearance	mm	140
Turning circle	m	10.7
Tank capacity	app ltr	51
Cooling system incl heater	ltr	7.2 (7.5 <sup>1</sup> )
Engine oil	ltr	5.5
Transmission fluid	ltr	Lifetime
Final drive fluid	ltr	Lifetime
Weight, unladen, to EU <sup>2)</sup>	kg	1,585 (1,595)
Max load to DIN	kg	440
Max permissible	kg	1,950 (1,960)
Max axle load, front/rear	kg	905/1,095
Max trailer load <sup>3)</sup>		
Braked (12%/unbraked)	kg	1,200/720
Max roofload/max towbar download	kg	–
Luggage compartment ISO 3832	ltr	260–305
Air drag	C <sub>d</sub> x A	0.32 x 2.09

### Power Unit

Config/No of cyls/valves		Straight/4/4
Engine management		DDE 71
Capacity, effective	cc	1,995
Bore/stroke	mm	90/84
Compression ratio	:1	16.0
Fuel grade		Diesel
Max output	kW/hp	130/177
at	rpm	4,000
Max torque	Nm/lb-ft	350/258
at	rpm	1,750–3,000

### Electrical System

Battery/installation	Ah/–	90 (80)/lug comp
Alternator	A/W	180/2,520

### Chassis and Suspension

Suspension, front		Double-joint tiebar spring strut axle, aluminium
Suspension, rear		Five-arm axle, lightweight steel
Brakes, front		Single-piston swing-calliper disc bakes
Diameter	mm	Vented/300 x 24
Brakes, rear		Single-piston swing-calliper disc bakes
Diameter	mm	Vented/300 x 20
Driving stability systems		ABS, CBC, ASC, DSC, DTC, DBC
Steering		Rack-and-pinion steering; 3.0 turns; EPS Electric Power Steering
Steering transmission ratio, overall	:1	16.0
Gearbox		H wide (6HP19TU)
Gear ratios I	:1	5.140 (4.171)
II	:1	2.830 (2.340)
III	:1	1.804 (1.521)
IV	:1	1.257 (1.143)
V	:1	1.0 (0.867)
VI	:1	0.831 (0.691)
R	:1	4.638 (3.403)
Final drive ratio	:1	2.64 (3.15)
Tyres, front		205/55 R16 91V RSC
Tyres, rear		205/55 R16 91V RSC
Rims, front		7J x 16 Steel
Rims, rear		7J x 16 Steel

<b>BMW 120d</b>		
<b>Performance</b>		
Power-to-weight ratio, DIN	kg/kW	11.6 (11.7)
Output per litre	kW/hp	65.2/88.7
Acceleration 0–100 km/h	sec	8.1 (8.2)
0–1000 m	sec	29.1 (29.2)
80–120 km/h in 4th/5th gear	sec	6.8/8.5 (–)
Top speed	Km/h	222 (220)
<b>Fuel Consumption in EU Cycle</b>		
Urban	ltr/100 km	6.4 (7.4)
Extra-urban	ltr/100 km	4.3 (4.5)
Composite	ltr/100 km	5.1 (5.6)
CO <sub>2</sub>	g/km	134 (148)
<b>Miscellaneous</b>		
Emission rating		EU4
		–

<sup>1)</sup> Figures in brackets apply to models with automatic transmission.  
<sup>3)</sup> May be increased under certain conditions.

<sup>2)</sup> Weight of vehicle in road trim (DIN), plus 75 kg for driver and luggage.  
<sup>4)</sup> Data not yet available at time of print.



# 11. Exterior and Interior Dimensions.



## Exterior dimensions closed.

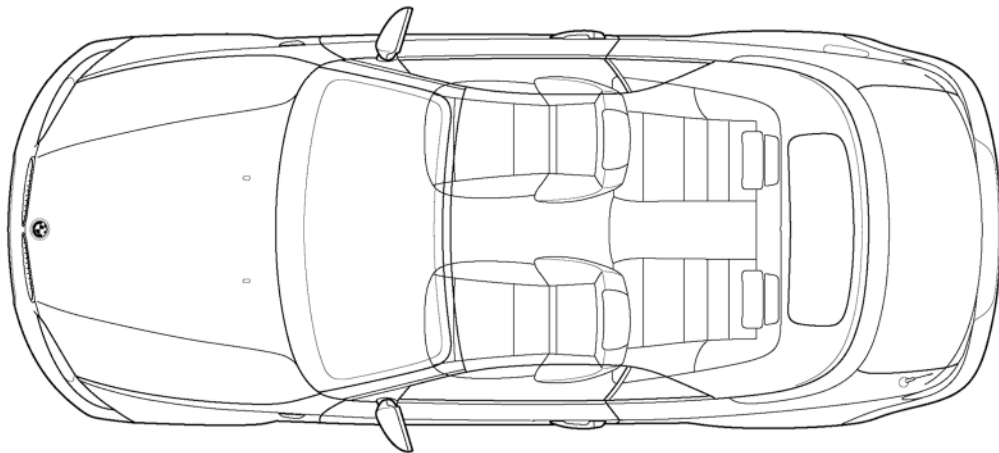
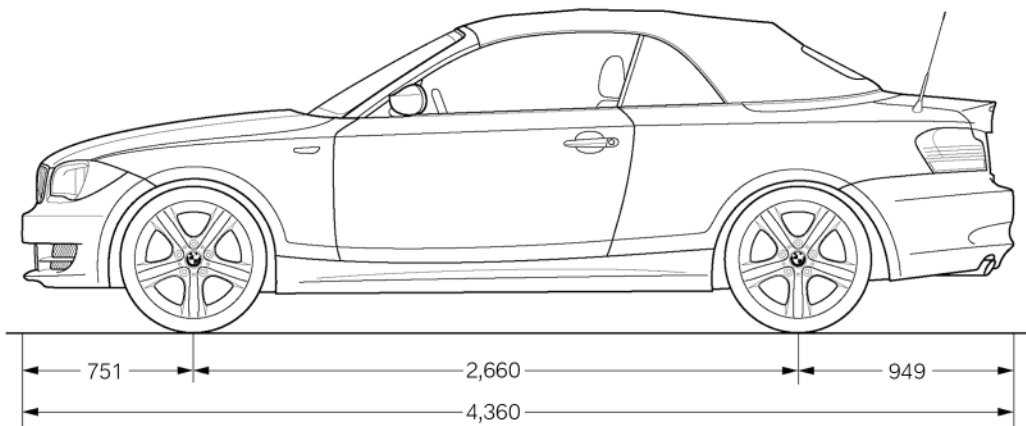
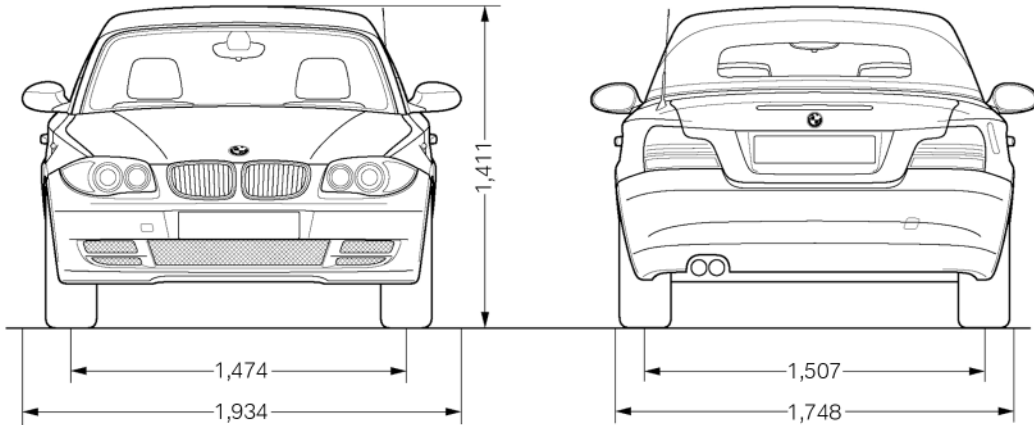

**Exterior dimensions opened.**

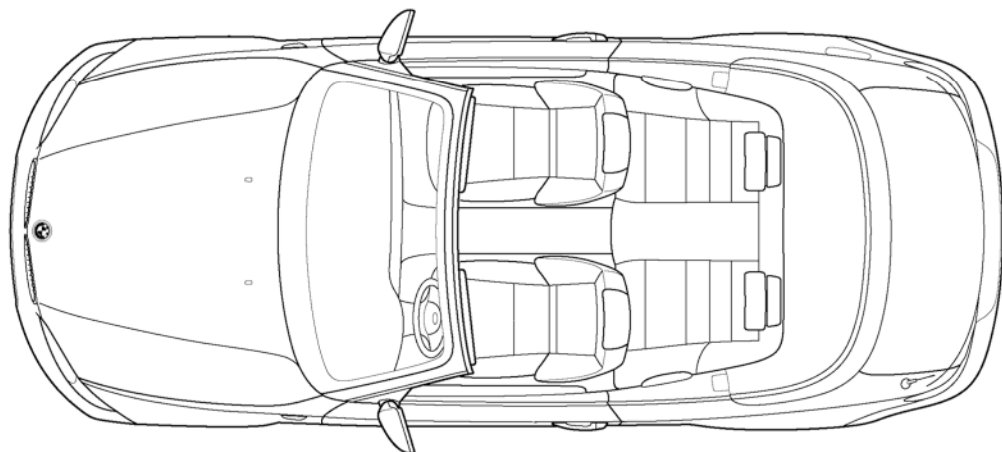
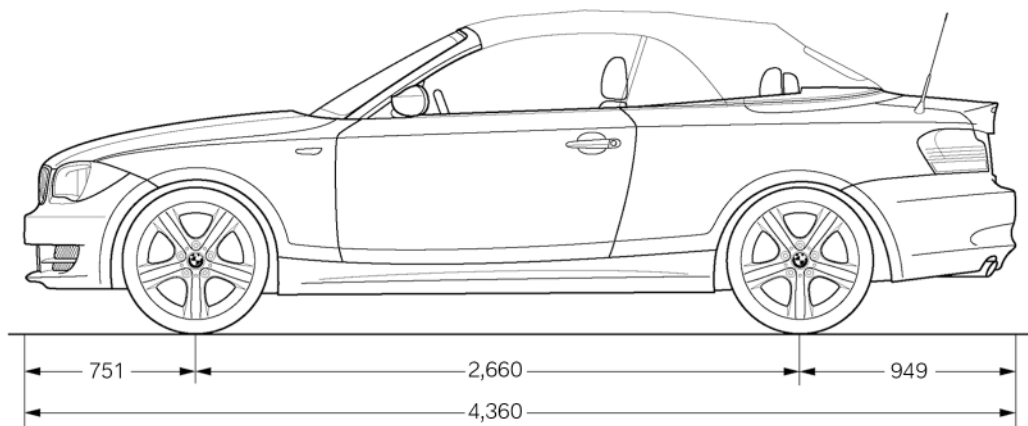
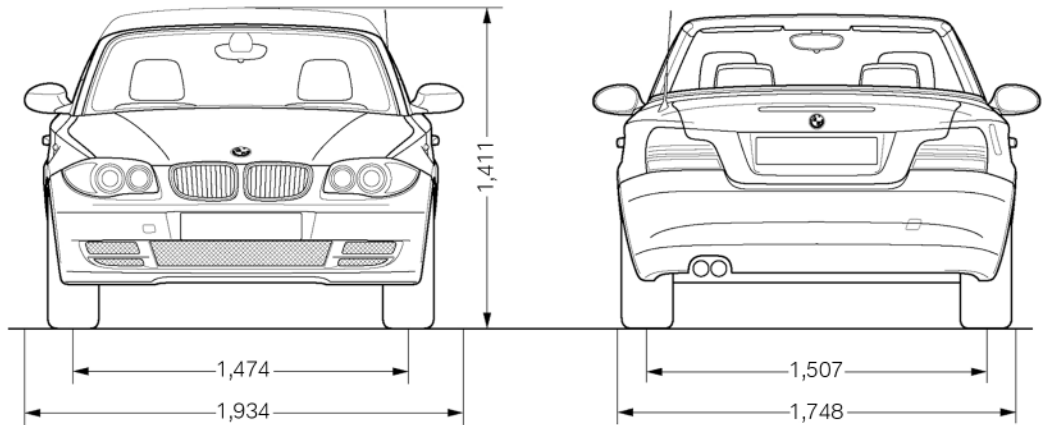

**Interior dimensions closed.**

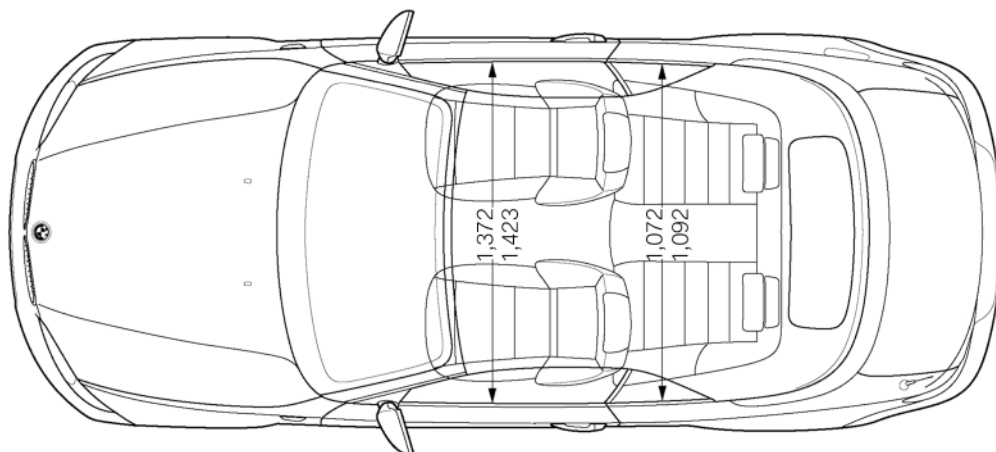
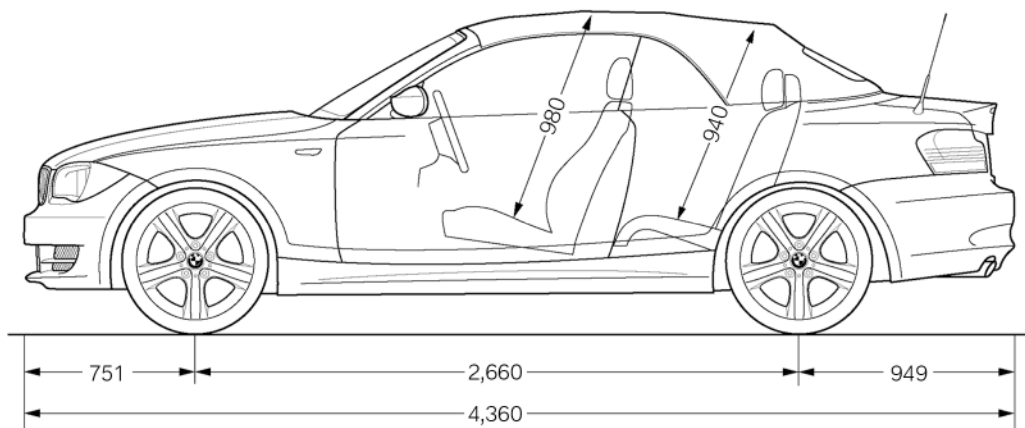
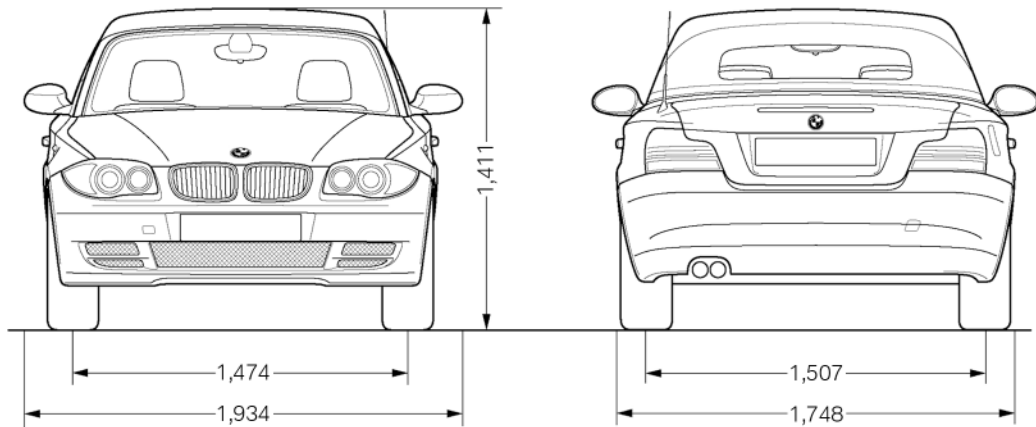

**Interior dimensions opened.**

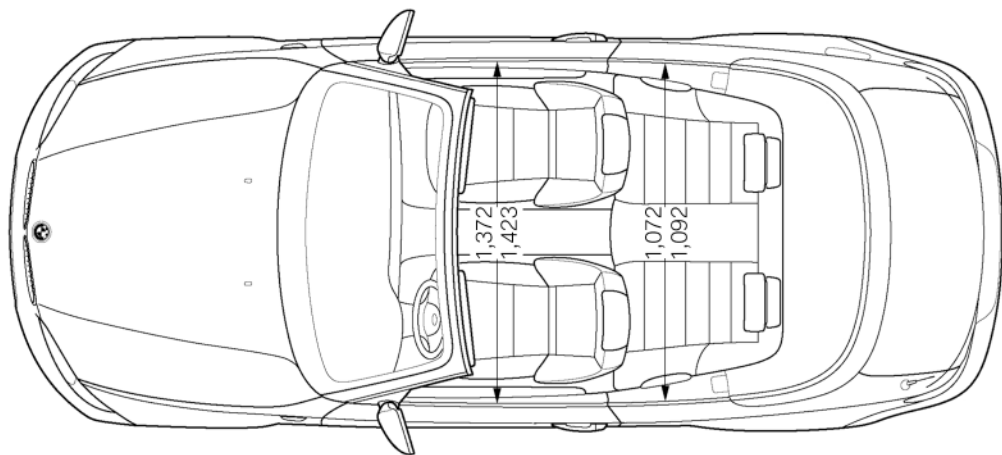
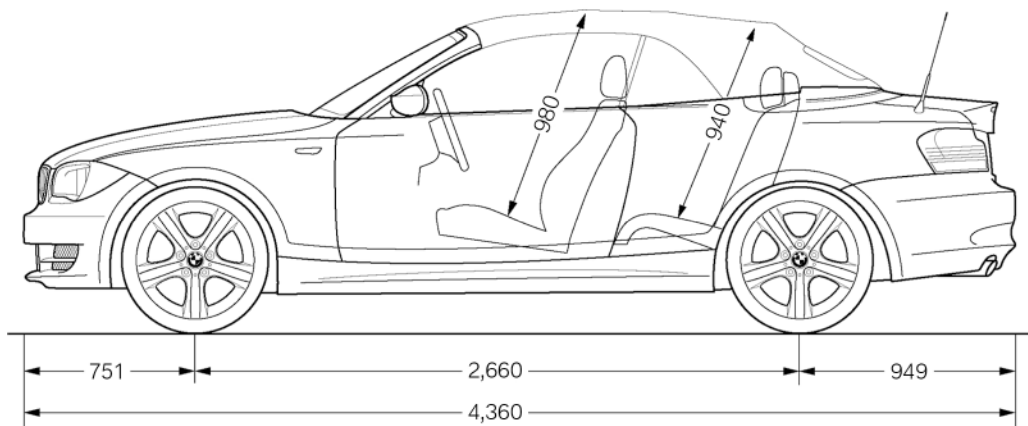
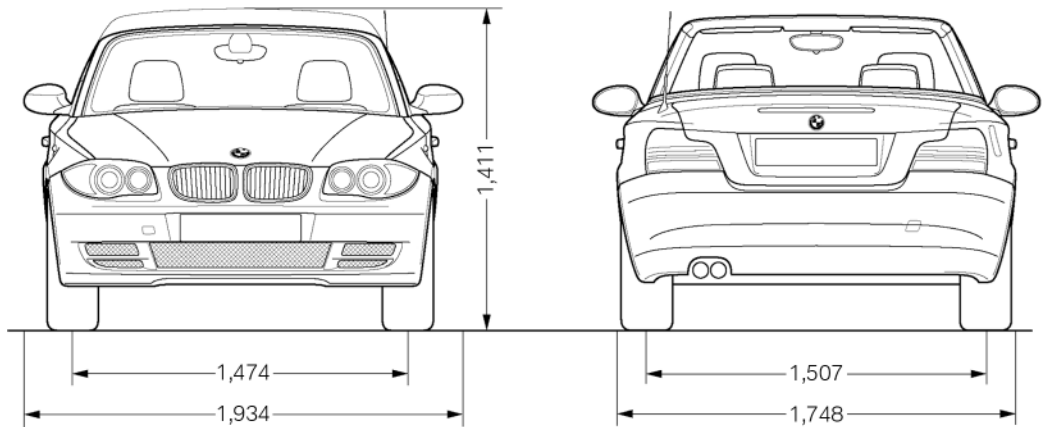

# 12. Power and Torque Diagrams.



## BMW 118i.

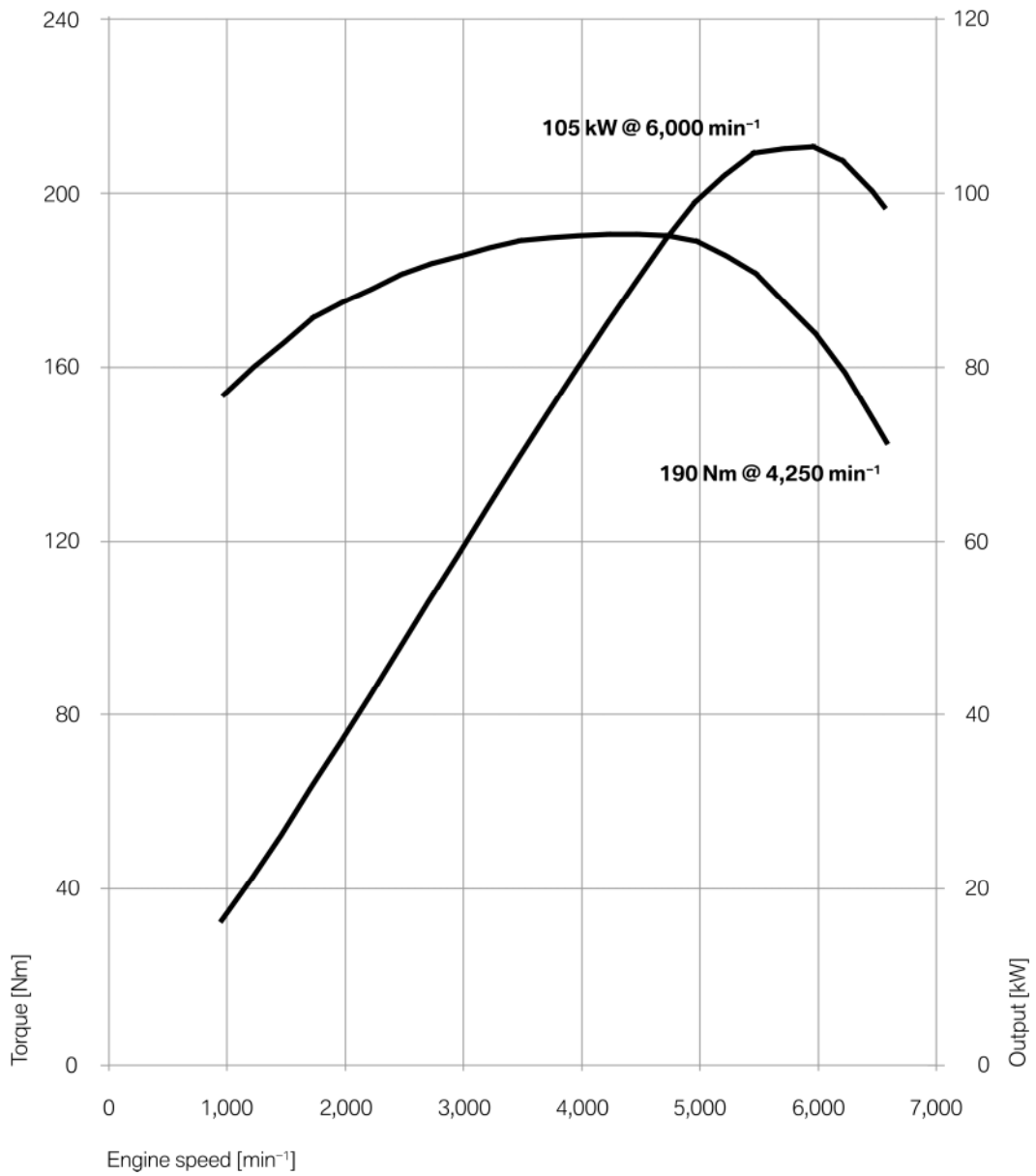

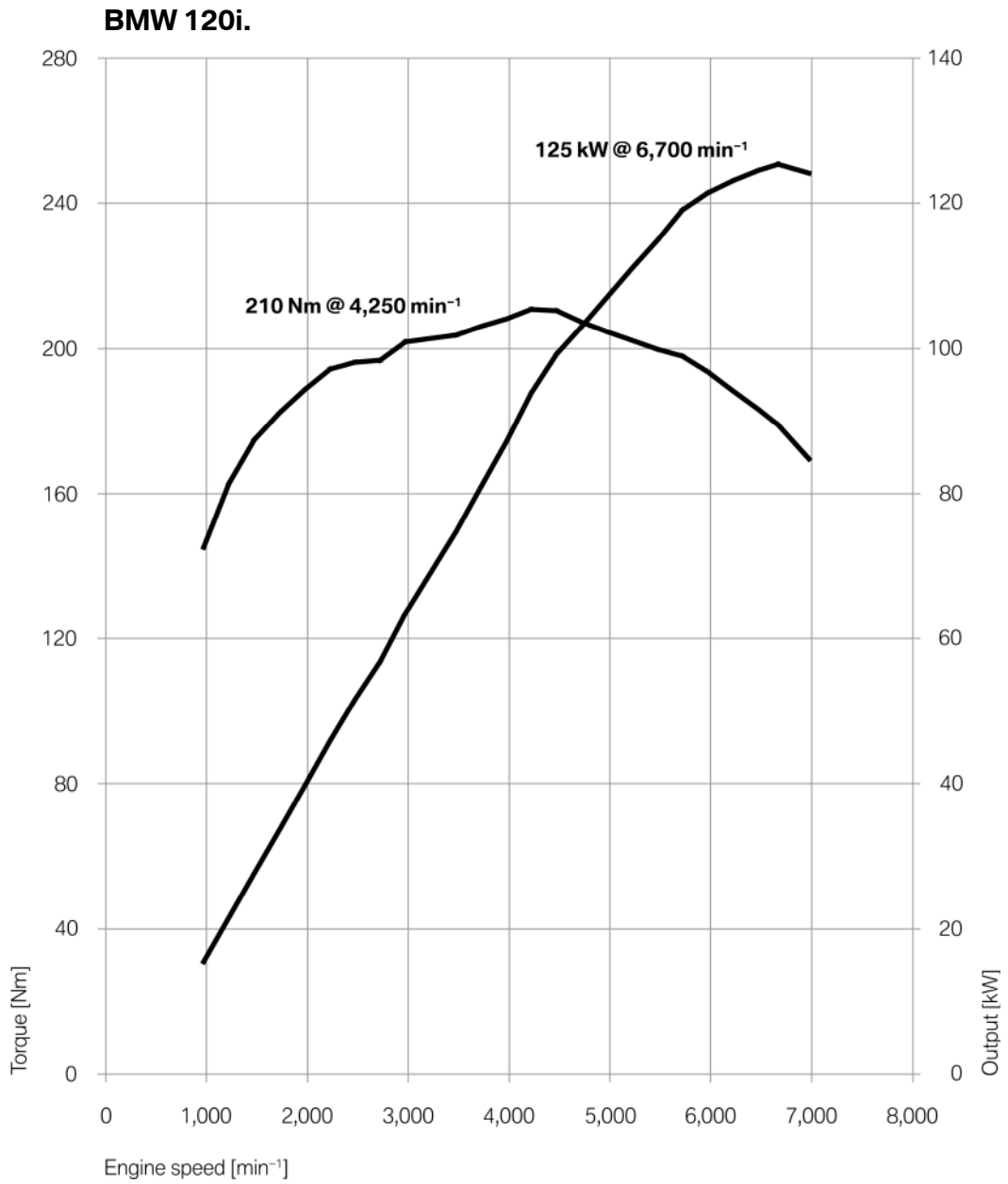

### BMW 125i.

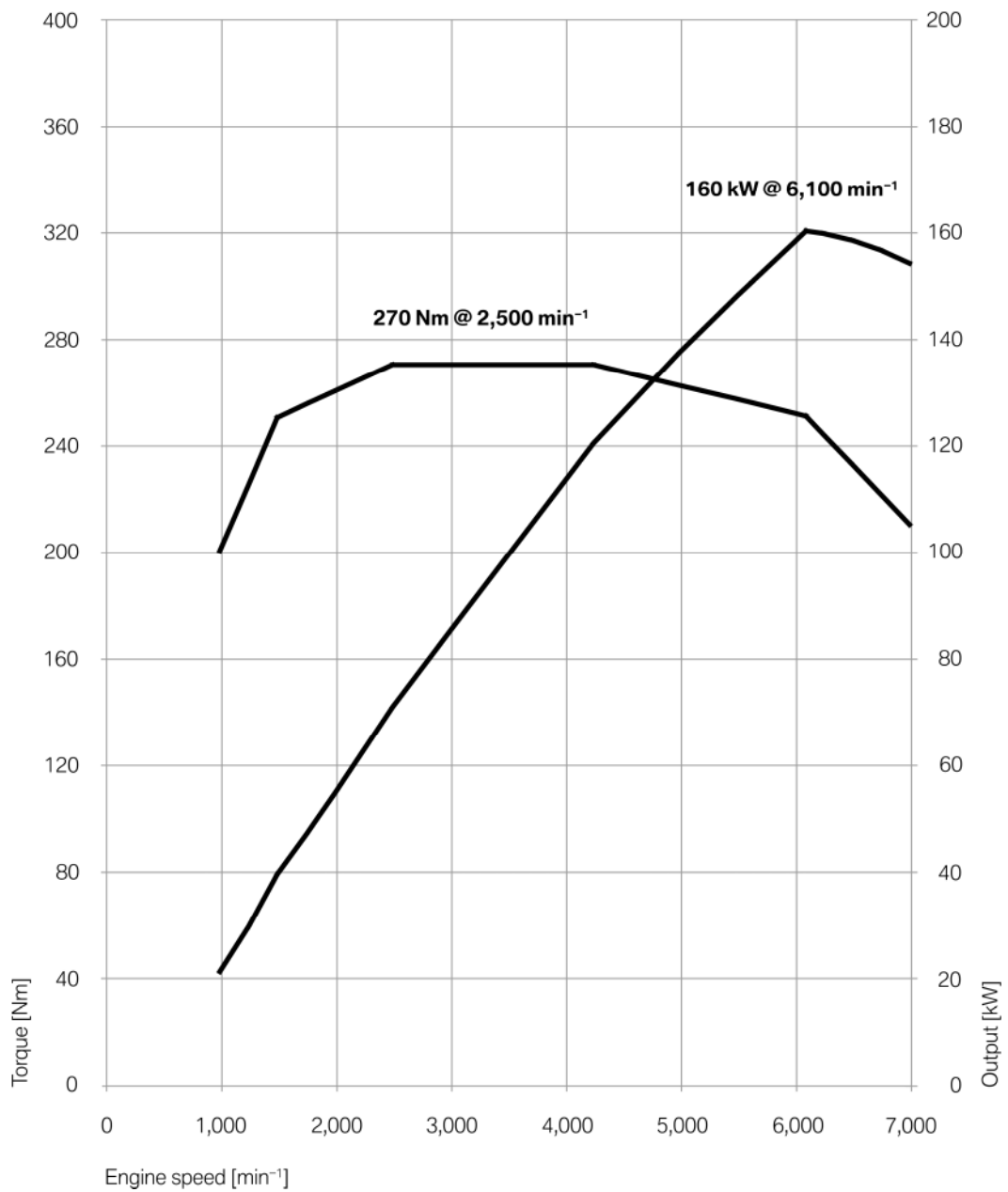

### BMW 135i.

